



REHAU RADIANT HEATING SYSTEMS

DESIGN GUIDE

TABLE OF CONTENTS

1. Scope	3	6. System Design.	36
2. Design Considerations	4	6.1. . . . Step 1 - Gather Documents and Specs	36
3. System Overview	5	6.2. . . . Step 2 - Determine Heat Output	36
3.1 . . . Applications	5	6.3. . . . Step 3 - Determine Surface Temps	36
3.2 . . . Thermal Comfort.	5	6.4. . . . Step 4 - Check Temperature Limitations	36
3.3 . . . Energy Efficiency	6	6.5. . . . Step 5 - Select Construction Method.	37
3.4 . . . Thermal Zoning	6	6.6. . . . Step 6 - Select Pipe Size	40
3.5 . . . Construction Methods	6	6.7. . . . Step 7 - Select Pipe Spacing	40
4. System Components.	7	6.8. . . . Step 8 - Determine Pipe Length	41
4.1 . . . Pipes	7	6.9. . . . Step 9 - Calculate Heating Water Temp	41
4.2 . . . Fittings - EVERLOC	24	6.10. . . Step 10 - Calculate Heating Water Flow	42
4.3 . . . Fittings - Compression Nut	25	6.11. . . Step 11 - Size Manifold	42
4.4 . . . Manifolds	26	6.12. . . Step 12 - Locate Manifold	42
4.5 . . . Heat Transfer Panels	26	6.13. . . Step 13 - Layout Pipe	44
4.6 . . . Heat Transfer Plates	27	7. System Testing	45
4.7 . . . Installation Accessories	27		
5. System Planning.	28		
5.1 . . . Building Layout.	28		
5.2 . . . Building Heat Loss	28		
5.3 . . . Room and Building Temperatures.	28		
5.4 . . . Building Zoning.	29		
5.5 . . . Insulation	29		
5.6 . . . Floor Coverings.	29		
5.7 . . . Wet Construction Joints.	31		
5.8 . . . Heat Source	32		
5.9 . . . Heating Water Controls	33		
5.10 . . . Manifolds	34		
5.11 . . . Circulator Pumps	34		

1. SCOPE

This technical information applies to the planning, installation and connection of REHAU radiant heating systems using PEXa crosslinked polyethylene pipe.

Persons using this guide must be experienced and appropriately licensed hydronic heating system designers, who have an understanding of the principles and practices for system design and installation.

The information presented in this guide is intended to demonstrate general methods and is not specific to your project conditions. It is the responsibility of the designer to check the prevailing local codes and to verify that technical information presented in this guide is appropriate for a particular installation. This guide does not supersede the recommendations of other manufacturers. If there is conflicting information, the designer must consult with the other manufacturer's representative prior to planning, installing and connecting the radiant heating system.

After reading this guide, designers should attend the Skill Builders seminar offered by the REHAU Academy, where design techniques for radiant heating systems are more fully explored. Designers should also periodically check the REHAU Resource Center for the latest updates.

This guide should be used in conjunction with the REHAU *Sustainable Building Technology Product Catalog* which provides a detailed description of each system component and the REHAU *Radiant Heating Installation Guide* which provides guidelines for system installation. The designer should also review the REHAU *PEXa Limited Warranty* and pertinent supplemental REHAU *Technical Bulletins* before beginning to design a radiant heating system.

Heat loss calculation methods are not covered. This guide assumes the designer has already calculated the building heat loss using an approved standard or equivalent engineering calculation.

If you do not have prior experience with hydronic heating systems or require additional assistance, please contact your regional REHAU sales office.

 This symbol and the signal words DANGER, WARNING or CAUTION alert you to personal injury hazards. If you don't avoid the hazardous situation:

- DANGER! Will result in death or serious injury
- WARNING! Could result in death or serious injury
- CAUTION! Can result in minor or moderate injury

The signal word NOTICE is used to help you avoid property damage. We cannot warn of all hazards; you must also use your own good judgment.

2. DESIGN CONSIDERATIONS

The most critical points in a radiant system design are:

- To consider the impact of the radiant floor construction methods to avoid problems during installation. Some examples are the additional step height with an overpour, additional load requirements on the structure, additional cure time for wet construction methods. (*REHAU Radiant Heating Installation Guide*)
- To correctly calculate and control the maximum heating water and flooring temperatures to avoid damaging hardwood floors or other flooring materials. (Chapter 5.6 and 5.9)
- To design with the correct construction methods for the conditions. For example, using heat transfer plates instead of talons to secure pipe under subfloors, or ensuring sufficient insulation around slabs. (Chapter 6.5)
- To completely think through the piping layout to avoid disadvantages such as pipe lengths that are too long, inconvenient manifold locations and cold spots. (Chapter 5.10 and 6.13)
- To design with the correct pipe spacing for the conditions; using pipe spacing that is too wide may result in striping and inconsistent floor temperatures. (Chapter 6.7)
- To correctly calculate the heat output of the radiant heating system to avoid wrong-sizing the system. (Chapter 6.2)
- To completely think through the heat source, controls and hydronic distribution piping to avoid inflating costs and to use energy efficiently. (Chapter 5.8, 5.9 and 5.10)

3. SYSTEM OVERVIEW

3.1 Applications

The REHAU radiant heating system works by circulating warm water through a network of pipes placed in the floor, wall or ceiling. Heat is gently radiated from these radiant panels into occupied spaces, warming the objects in the area to create a comfortable environment. Radiant heating can be installed in a single room or throughout an entire building, and it is particularly ideal for areas with high ceilings. There are no radiators, unit ventilators or outlet air vents—giving the owner more design freedom and open space. A variety of heat sources can be used, including boilers, geothermal heat pumps, solar collection systems and water heaters.

REHAU radiant heating has been installed in a wide range of building types including:

Residential	Single- or Multi-Family Homes, Apartments, Basements, Garages
Commercial	Hotels, Offices, Restaurants, Warehouses, Car Dealerships, Auto Garages, Museums, Day Care Facilities, Retirement Homes
Industrial	Warehouses, Garages, Factories, Hangars
Agricultural	Barns, Greenhouses
Institutional	Schools/Colleges, Hospitals, Prisons, Fire Stations, Bus Stations

3.2 Thermal Comfort

Heat emission from the human body occurs mainly via three mechanisms: radiation, evaporation and convection. Humans feel most comfortable when they can regulate at least 50% of their heat emission via radiation, and when their feet are warmer than their heads.

Radiant heating systems provide heat on the basis of low heating surface temperatures over a large area and an even air temperature distribution with mild, comfortable radiated energy. In contrast to conventional forced-air systems, a radiative equilibrium is generated between people and the surfaces throughout the room, thus nearly achieving the optimum thermal comfort level. The occupant's thermal comfort level is found at relatively lower ambient room temperatures due to the radiative effect of the radiant heating system. This allows the design setpoint for the ambient room temperature to be lowered by 2 to 4°F (1 to 2°C). There is hardly any air movement, unlike forced-air systems which convey heat using air exchange with the following negative effects: warm and cold blasts of air near registers and returns, drafts in the room due to the high air speed and air stratification in the room. Radiant heating systems more closely match the optimum thermal comfort profile compared to other heating systems (see Fig. 3.1).

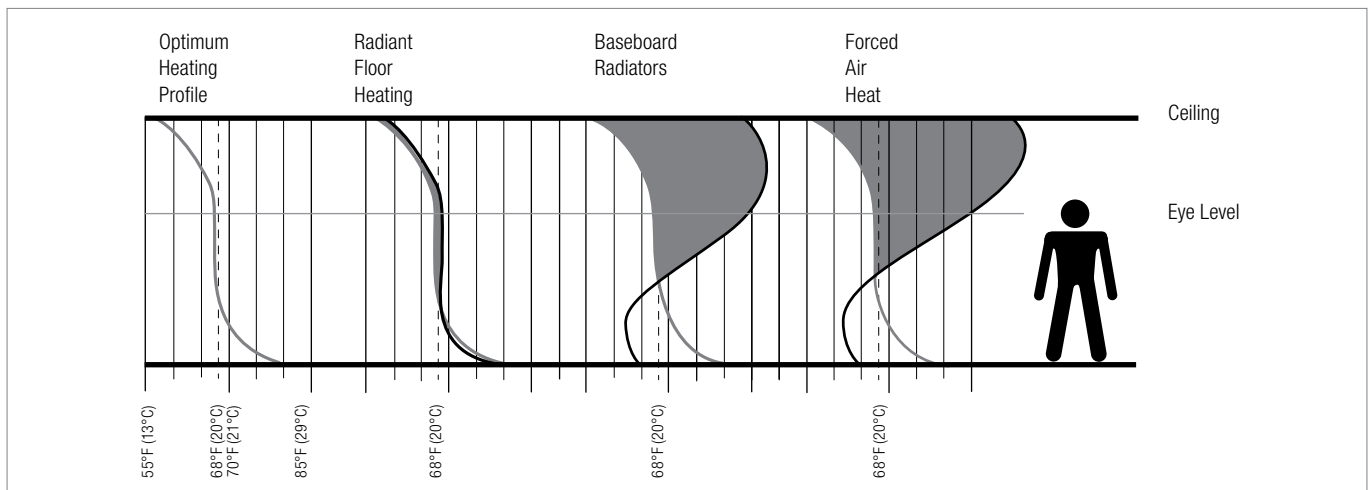

Fig. 3.1: Optimum heating distribution compared to representative temperature profiles for radiant, baseboard and forced-air heating.

3.3 Energy Efficiency

Many new buildings are being designed to achieve certifications, such as LEED, Energy Star, or the NAHB National Green Building Program. Legislation is requiring improved insulation of structures, infiltration testing and heat loss design methods. Radiant heating systems are very capable of meeting these high standards. The energy efficiency of radiant walls, floors and ceilings comes from the following key factors:

- Maintains thermal comfort in a room at a lower ambient room temperature
- Delivers heat more efficiently than other systems
- Loses no heat through ducts
- Results in less air infiltration

The efficiencies with radiant heating systems can translate into annual energy savings for the building owner.

Note: Uncontrolled human factors, such as changing the design temperatures, can dramatically affect efficiency and energy usage of any system.

3.4 Thermal Zoning

A thermal zone is an area of temperature control. Zoning the temperature in different areas of the building is generally required in commercial, industrial and institutional installations, and may also be desirable in residential installations.

Advantages of zoning include:

- Establishing different room temperatures based on comfort levels
- Reducing unoccupied room temperatures to save energy
- Reacting to heat input from occupants
- Reacting to heat input from solar gain
- Fine-tuning heat output into each room

3.5 Construction Methods

Radiant heating systems are installed in floors using wet or dry construction methods. It is compatible with a variety of floor coverings, including hardwood, carpet, vinyl, ceramic tile and natural stone. Radiant heating may also be installed in walls and ceilings using the dry panel construction.

Wet Construction

Slab on grade	Structural slab	Overpour above existing subfloor
---------------	-----------------	----------------------------------

Dry Construction

Heat transfer panels above subfloor (dry panel)	Heat transfer panels below floor in joist spaces (dry plate)
---	--

Wet Construction Methods

Wet construction of a radiant panel system embeds the pipe in a thick concrete slab, or in a thin layer of gypsum, lightweight concrete or mortar bed which is installed over a subfloor.

Dry Panel Construction Methods

A dry panel radiant heating system is installed directly on top of the subfloor without a concrete overpour. Pipes are installed in a grooved conductive panel. Dry panel systems are considered low mass and offer faster response times compared with wet systems.

Dry Plate Construction Methods

In a dry plate radiant heating system, pipes are installed in the joist spaces under a suspended wood floor. Heat transfer plates are used to evenly distribute the heat, increasing the efficiency of heat transfer from the pipe to the bottom of the subfloor.

4. SYSTEM COMPONENTS

REHAU offers pipes, fittings, manifolds, heat transfer panels and plates, controls, and a variety of installation accessories for radiant heating systems. For a detailed description of our system components, refer to REHAU *Sustainable Building Technology Product Catalog*.

4.1 Pipes

RAUPEX® crosslinked polyethylene (PEXa) pipe is manufactured using REHAU's high-pressure peroxide extrusion method that typically yields the highest, most consistent level of crosslinking. Pioneered by REHAU in 1968, PEXa technology enhances flexibility and thermal memory, providing ease of handling and kink repair while supporting the use of REHAU EVERLOC® compression-sleeve fittings.



Fig. 4.1: RAUPEX pipe

RAUPEX has distinct advantages over metal and other polymer pipes:

- Resists pitting and stress corrosion
- Resists scaling and deposit build-up when used with both hard and softened water
- Minimizes noise that is transmitted through pipes
- Withstands the high temperatures and pressures of hydronic heating systems
- Resists notching and abrasion damage

RAUPEX is manufactured by REHAU in a facility whose quality management system is ISO 9001 certified. Within the facility, REHAU receives and mixes the raw materials, then extrudes and ships the finished product. In addition, RAUPEX production is independently monitored at least annually by Underwriters Laboratories Inc. (UL), NSF International and CSA International.

4.1.1 Pipe Standards and Certifications

RAUPEX pipes are designed for use in radiant heating systems. They may also be used in other hydronic heating systems including baseboard radiators, fan coils, convective fin tube, panel radiators and kick space heaters as long as the temperature and pressure ratings are not exceeded.

RAUPEX pipes may not be used for applications such as steam systems, refrigerant lines and medical gases to name a few.

RAUPEX pipes meet the following requirements in the United States and Canada:

- NSF International Standard 14, *Plastic Piping System Components and Related Materials*
- NSF Standard 61, *Health Effects*
- CSA B137.5, *Cross-linked Polyethylene (PEX) Piping Systems for Pressure Applications*
- ASTM F876, *Standard Specification for Cross-linked Polyethylene (PEX) Piping*
- ASTM F877, *Standard Specification for Cross-linked Polyethylene (PEX) Plastic Hot and Cold Water Distribution Systems*
- ASTM F2080, *Standard Specification for Cold-expansion Fittings with Metal Compression Sleeves for Cross-linked Polyethylene (PEX) Pipe*
- ASTM F2023, *Chlorine Resistance of Cross-linked Polyethylene (PEX) Pipe*
- Plastic Pipe Institute TR-3, *Standard Grade Listing Complying with the Full Data Requirements of ASTM D2837, Listed in PPI TR-4*
- ICC Evaluation Report, ESR-1576
- U.S. Department of Housing and Urban Development (HUD) Material Release No. MR1296c

RAUPEX pipes are accepted by the following model codes:

- IMC International Mechanical Code (IMC)
- International Building Code (IBC)
- International Residential Code (IRC)
- Uniform Building Code (UBC)
- Uniform Mechanical Code (UMC)
- National Building Code of Canada (NBC)

RAUPEX pipes can be used in radiant systems as described in:

- CSA B214, *Installation Code for Hydronic Heating Systems*
- Radiant Panel Association *Guidelines for the Design and Installation of Radiant Panel Heating and Snow/Ice Melt Systems*
- ASHRAE 2008 *Handbook HVAC Systems and Equipment, Chapter 6 Panel Heating and Cooling*

4.1.2 Pipe Applications

REHAU provides three types of RAUPEX pipes for different applications; all three types have the same temperature and pressure capabilities.

4.1.3 Pipe Dimensions

RAUPEX pipe is available in nominal sizes ranging from 3/8 to 2 in. Pipe is in accordance to the dimensional standards defined in ASTM F876. RAUPEX pipe is copper pipe size (CTS) outside diameter (OD), which means that the actual OD of the pipe is 1/8 in (3.18 mm) larger than the nominal OD.

Wall thickness is defined by the standard dimensional ratio (SDR). RAUPEX pipe is SDR 9, which equates to the outside diameter being approximately nine times the wall thickness.

Table 4.1: Types of RAUPEX Pipes

RAUPEX Type	Typical Application	Characteristics	Description
RAUPEX O ₂ Barrier	Radiant Heating	- Has oxygen diffusion barrier (EVOH) to limit oxygen permeation - Color: bright red	Pipe provides superior protection to ferrous components
RAUPEX UV Shield	Potable Plumbing	- Has colored HDPE outer layer to improve protection against UV light - Does not have oxygen diffusion barrier - Colors: matte red, blue, white	Pipe is protected (for a limited time) from UV exposure during construction before the wall coverings are installed
RAUPEX Non-Barrier	Fire Protection	- Does not have oxygen diffusion barrier - Has limited UV protection - Color: natural white	Pipe markings are permanent which is a mandatory requirement

Note: UV Shield and Non-Barrier pipe may be used with radiant heating systems in conjunction with non-ferrous components.

Table 4.2: RAUPEX Pipe Dimensions per ASTM F876

Pipe Size	Average OD in (mm)	Minimum Wall Thickness in (mm)	Weight lb/ft (kg/m)	Capacity gal/ft (l/m)
3/8 in	0.500±0.003 (12.70±0.08)	0.070 (1.78)	0.05 (0.07)	0.0050 (0.0624)
1/2 in	0.625±0.004 (15.88±0.10)	0.070 (1.78)	0.06 (0.08)	0.0098 (0.1222)
5/8 in	0.750±0.004 (19.05±0.10)	0.083 (2.12)	0.08 (0.11)	0.0134 (0.1671)
3/4 in	0.875±0.004 (22.22±0.10)	0.097 (2.47)	0.10 (0.15)	0.0189 (0.2356)
1 in	1.125±0.005 (28.58±0.12)	0.125 (3.18)	0.17 (0.26)	0.0316 (0.3939)
1-1/4 in	1.375±0.005 (34.92±0.12)	0.153 (3.88)	0.25 (0.37)	0.0467 (0.5827)
1-1/2 in	1.625±0.006 (41.28±0.16)	0.181 (4.59)	0.35 (0.52)	0.0650 (0.8118)
2 in	2.125±0.006 (53.98±0.16)	0.236 (6.00)	0.60 (0.90)	0.1114 (1.3906)

4.1.4 Pipe Performance Characteristics

Pressure and Temperature Ratings

RAUPEX pipe has been tested in accordance with the Plastic Pipe Institute (PPI) TR-3/2003 policy to determine the long-term hydrostatic strength of the pipe. The PPI policy is based on ASTM D2837, *Standard Test Method for Obtaining Hydrostatic Design Basis for Plastic Pipe Materials*. Accordingly, RAUPEX pipe has continuous ratings at the following pressures and temperatures:

- 160 psi (11 bar) @ 73.4°F (23°C)
- 100 psi (7 bar) @ 180°F (82°C)

These pressure ratings are derived from an extrapolated time-to-failure prediction based on minimum requirements as defined in ASTM F876. Refer to PPI TR-3 for further explanation of these continuous use ratings.

NOTICE: To avoid damage to the pipe and reduction of expected operating lifetime, radiant heating designs must not exceed the pipe pressure and temperature ratings.

- Designer must properly determine the maximum operating pressure, taking elevation differences within the piping system into account.
- Designer must not locate RAUPEX pipe near heat sources such as recessed canned lights or exhaust flues. Refer to the recommendations of the heat source manufacturer as well as the local code requirements to ensure proper clearances are incorporated into the design layout.

Table 4.3: UV Exposure Limits for RAUPEX Pipe

Types of RAUPEX Pipes	Maximum UV Exposure Time
RAUPEX Non-Barrier	15 days accumulated
RAUPEX O ₂ Barrier	30 days accumulated
RAUPEX White UV Shield	3 months accumulated
RAUPEX Red and Blue UV Shield	1 year accumulated

Ultraviolet Resistance

Plastics are susceptible to damage from exposure to the ultraviolet (UV) radiation in sunlight. PEX pipes can be designed to protect against short-term UV damage, but after some time, UV radiation will reduce the lifespan of the pipe. The extent of the reduction depends on factors such as temperature, pressure and chlorination levels in potable water. If excessive UV exposure occurs, a PEX pipe may not last its full design life.

REHAU has performed extensive testing of RAUPEX pipes exposed to natural sunlight, leading to the maximum UV exposure times expressed in accumulated days shown in Table 4.3. Once the pipes leave the manufacturing plant, any exposure to UV, including transportation and storage by the wholesaler, is part of the accumulated exposure time.

RAUPEX pipes must not be stored outdoors and are not designed for permanent outdoor exposure (with the exception of buried applications).

NOTICE: Failure to follow maximum UV exposure limits may damage the pipe resulting in leaks and operational failures, and will negate any warranty provided by REHAU for RAUPEX pipes.

Oxygen Diffusion Properties

In typical radiant heating systems, hundreds or thousands of feet of RAUPEX pipe will be used, providing a large surface area for potential permeation of oxygen. The uncontrolled diffusion of oxygen into closed radiant heating systems is an important issue for system designers. The oxygen diffusion barrier on RAUPEX O₂ Barrier pipe limits oxygen permeability as defined within DIN 4726, the accepted German standard for limiting oxygen diffusion. Without an oxygen diffusion barrier, oxygen (O₂) can pass through the pipe wall, dissolve in the heating water and corrode any ferrous components such as pipes, valves, pumps and boilers. Concrete does not protect the system because it is porous and oxygen can easily pass through it.

NOTICE: Use only O₂ Barrier pipe in heating systems with ferrous components. Excessive oxygen in system may damage ferrous components resulting in leaks and operational failures.

Chemical Compatibility

RAUPEX pipe is compatible with ethylene and propylene glycol, and common corrosion inhibitors used in hydronic piping systems. Chemicals that may damage RAUPEX pipe include (but are not limited to):

- Adhesives
- Oil or petroleum-based products
- Paints
- Solvents
- Oxidizing agents (e.g., bleach)
- Disinfectants (e.g., separate dosing unit integrated into building distribution system)

Many factors, such as exposure time, temperature, pressure and other operating parameters, can influence the performance of a pipe that is exposed to a chemical. To determine the impact of a particular chemical, short- and long-term pressure testing may be required. In some cases, a pipe may be resistant to short-term exposure to the chemical, but not resistant to continuous exposure. Each chemical must be evaluated individually.

NOTICE: Check compatibility before allowing chemicals to come in contact with the exterior or interior of RAUPEX pipe. Chemicals may damage the pipe resulting in leaks and operational failures.

Excessive Temperature and Pressure Capability

Temperature and pressure (T&P) relief valves are safety mechanisms in case the system overheats (mandatory in hot water distribution systems). These valves act quickly to relieve excess temperature or pressure if either one of these conditions is reached. In the event of a water heating system failure or T&P relief valve failure, RAUPEX pipe has been tested to accommodate short-term exposure conditions of 210°F (99°C) at 150 psi (10 bar) for 48 hours. The actual test to obtain this short-term excessive temperature pressure capability requires that the pipe and fittings withstand these conditions for at least 720 continuous hours (30 days). This properly ensures that all safety factors are met.

NOTICE: Failure to follow pressure and temperature limits may damage the pipe resulting in leaks and operational failures, and will negate any warranty provided by REHAU for RAUPEX pipes. The designer must incorporate proper controls into the system to ensure the pressure and temperature capability of the pipe is not exceeded.

Friction Loss

RAUPEX pipe has a Hazen-Williams coefficient C-value of 150. Tables 4.8 to 4.12 list pressure loss per 100 ft of pipe for various flow rates, water temperatures and propylene glycol concentrations. This information is based on ASTM F876 size PEX pipe.

Table 4.4: Physical Properties of RAUPEX Pipes

Specification	Imperial	SI	Standard
Minimum Density	58 lb/ft ³	926 kg/m ³	ASTM F876
Degree of Crosslinking	70-89%	70-89%	ASTM F876
Thermal Conductivity	0.24 Btu·in/h·ft ² ·°F	0.41 W/m·°C	DIN 52612
Linear Expansion	9.33 x10 ⁻⁴ in/ft°F @ 68°F 1.33 x10 ⁻³ in/ft°F @ 212°F	0.14 mm/(m°C) @ 20°C 0.2 mm/(m°C) @ 100°C	DIN 42328
IZOD Impact Resistance	No Break	No Break	DIN 53453
Modulus of Elasticity	87,000 - 130,500 psi @ 68°F 43,500 - 58,000 psi @ 176°F	600-900 N/mm ² @ 20°C 300-400 N/mm ² @ 80°C	DIN 53457
Minimum Burst Pressure (1/2 in. Pipe)	480 psi @ 73.4°F 215 psi @ 180°F 185 psi @ 200°F	33.1 bar @ 23°C 14.8 bar @ 82°C 12.8 bar @ 93°C	ASTM F876
Tensile Strength	4194-4355 psi @ 68°F 2610-2900 psi @ 176°F	26-30 N/mm ² @ 20°C 18-20 N/mm ² @ 80°C	DIN 53455 ASTM D638
O ₂ Permeability	<=0.32 mg / m ² / day @ 40°C	<=0.32 mg / m ² / day @ 40°C	DIN 4726
Temperature Working Range	-40°F to 200°F	-40°C to 93°C	N/A
Roughness	e=0.00028 in	e=0.007 mm	N/A
Maximum Short-term Exposure	150 psi @ 210°F (48 hr)	10.3 bar @ 99°C (48 hr)	ASTM F876
Melt Temperature	752°F	400°C	N/A

Fire Resistance in Fire-Rated Assemblies

It is common to install radiant heating pipes through fire-rated wall and floor/ceiling assemblies. Building codes require this be done without diminishing the overall fire rating of the assembly. The fire-resistance of RAUPEX pipe has been tested to the following standards for the assemblies listed in Table 4.5:

- ANSI/UL 263, *Fire Tests of Building Construction and Materials*
- CAN/ULC-S101, *Standard Methods of Fire Endurance Tests of Building Construction and Materials*

The listing covers RAUPEX Non-Barrier, UV Shield and O₂ Barrier pipes ranging from 3/8 to 2 in.

Table 4.5: UL and ULC Design Listings

Fire-rated Assembly Description	UL Design	ULC Design
Reinforced Concrete Slab	No. K917	No. J900
Wood Framed Floor/Ceiling Assembly	No. L588	No. M516
Framed Bearing Wall	No. U383	No. W316
Framed Non-Bearing Wall	No. V461	No. W458

Refer to the online certifications directories from UL (www.ul.com) or ULC (www.ulc.ca) for additional details on the design listings.

⚠ WARNING: When using RAUPEX pipe in fire-rated assemblies, the specifying engineer and designer must evaluate the design listing to ensure that local code requirements are met. Fire or smoke that is not contained may lead to death or serious injury. The Authority Having Jurisdiction should review and approve the design before installation.

Building codes require installation of an approved through-penetration firestop system where pipes penetrate through a fire-rated assembly (i.e., floor, ceiling or wall). Some firestop products are listed for all assembly types, while others are listed for only specific assembly types. RAUPEX pipe is fire-stopped at both points of entry through the fire-rated assembly.

The firestop system must be tested in accordance with one or all of the following standards and listed by an independent third-party listing agency such as UL, ULC or ITS (Warnock-Hershey). The firestop system must meet all local code requirements prior to installation. The most common firestop system standards are:

- ASTM E-814, *Fire Tests of Through-Penetration Firestops*
- UL 1479, *Fire Tests of Through-Penetration Firestops*
- CAN/ULC S115-M, *Tests of Fire Resistance of Building Joint Systems*

When choosing an approved firestop system for each specific installation, the following information must be known:

- Nominal size of PEX pipe penetrating the fire-rated assembly
- Number of PEX pipes penetrating through one opening
- Construction of fire-rated assembly (e.g., wood or concrete)
- The "F" and "T" ratings of the fire-rated assembly
- Type of assembly being penetrated (e.g., floor, ceiling or wall)

NOTICE: The designer must ensure the firestop materials are compatible with the RAUPEX pipe. Chemicals may damage the pipe resulting in leaks and operational failures.

Flame and Smoke Spread Ratings

A plenum is an enclosed portion of a building structure that is designed to allow air movement, thereby serving as part of an air distribution system. Plenums can serve as supply, return, exhaust and ventilation portions of the air distribution system.

Typically, building codes require that combustible materials installed within air plenums have a flame spread rating of not more than 25, and a smoke developed rating of not more than 50. These ratings are assigned during standardized laboratory tests that burn the combustible pipe and measure the speed of flame spread and the volume of smoke developed. Pipes that meet these requirements are sometimes said to have a "plenum rating."

United States and Canada have different, but similar, standards for this test. These standards are:

- ASTM E84, *Surface Burning Characteristics of Building Materials*
- CAN/ULC S102.2, *Standard for Surface Burning Characteristics of Flooring, Floor Covering and Miscellaneous Materials and Assemblies*

RAUPEX Non-Barrier, UV Shield and O₂ Barrier pipes (1/2 to 2 in. sizes) have been tested to both the US and Canadian standards.

Based on this testing, some sizes and types of RAUPEX require an outer jacket of fiberglass insulation that is listed to the E-84 and S102.2 standards.

Table 4.6: Fiberglass Insulation Requirements for RAUPEX in Plenum Spaces

Pipe Size and Type	ASTM E-84	CAN/ULC S102.2
1/2 in. RAUPEX O ₂ Barrier	Ø	Ø
1/2 in. RAUPEX UV Shield	Ø	Ø
1/2 in. RAUPEX Non-Barrier	Ø	Ø
3/4 in. RAUPEX O ₂ Barrier	+	Ø
3/4 in. RAUPEX UV Shield	+	Ø
3/4 in. RAUPEX Non-Barrier	+	Ø
1 in. RAUPEX O ₂ Barrier	+	+
1 in. RAUPEX UV Shield	+	+
1 in. RAUPEX Non-Barrier	+	Ø
1 1/4 in. RAUPEX O ₂ Barrier	+	+
1 1/4 in. RAUPEX UV Shield	+	+
1 1/4 in. RAUPEX Non-Barrier	+	+
1 1/2 in. RAUPEX O ₂ Barrier	+	+
1 1/2 in. RAUPEX UV Shield	+	+
1 1/2 in. RAUPEX Non-Barrier	+	+
2 in. RAUPEX O ₂ Barrier	+	+
2 in. RAUPEX UV Shield	+	+
2 in. RAUPEX Non-Barrier	+	+

+ required Ø not required

Freeze Break Resistance

The flexibility of the RAUPEX pipe allows it to expand as water freezes in the pipe as long as the pipe has room to expand. When the water thaws, the pipe returns to its original shape. If the pipe is not allowed to expand (e.g., it is encased in concrete), it may burst.

NOTICE: Designers must take precautions to ensure that pipes do not freeze. Frozen pipes may burst resulting in leaks and operational failures.

Chlorine Resistance

RAUPEX pipe has been tested by NSF International in accordance with ASTM F2023, *Standard Test Method for Evaluating the Oxidative Resistance of Cross-linked Polyethylene (PEX) Tubing and Systems to Hot Chlorinated Water* as required in ASTM F876. RAUPEX pipe exceeds the minimum extrapolated test lifetime as certified by NSF and PPI for cold water applications, intermittent hot water applications and timed hot water applications.

Linear Expansion and Contraction of RAUPEX Pipe

Embedding RAUPEX pipe in concrete or securing it in RAUPANEL or RAUPLATE restricts its ability to expand and contract. Unrestrained pipe will expand and contract when heated and cooled. To accommodate the operating expansion and contraction of RAUPEX pipe, a deflection leg may need to be incorporated into the pipe layout.

The amount of expansion or contraction in a length of RAUPEX pipe is calculated using the equation:

$$\Delta L = L \times \Delta T \times \alpha$$

where

- ΔL change in length
- L original length
- ΔT change in temperature
- α coefficient of expansion.

In general, RAUPEX pipe expands approximately 1 inch per 100 ft for every 10°F rise in temperature (or approximately 10 mm per 10 m for every 6°C).

4.1.5 Pipe Markings

Pipe markings are repeated every 3 ft (0.9 m), list all certifications and approvals, and include an incremental footage marking to assist with installing the pipe. RAUPEX pipe is further identified with a PEX Material Designation code in accordance to ASTM F876.

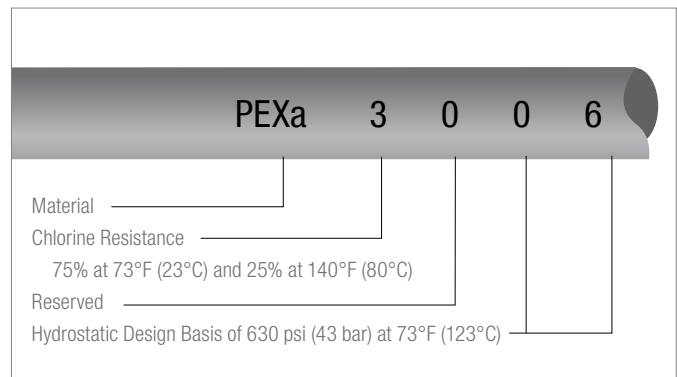

Fig. 4.2: Example RAUPEX O₂ Barrier Pipe Material Designation Code

4.1.6 Pipe Compatibility With PEX Fitting Systems

RAUPEX pipe is marked with the ASTM standard specification numbers of compatible PEX fitting systems.

4.1.7 Pipe Material Safety Data Sheet (MSDS)

The Occupational Safety and Health Administration (OSHA) Hazard Communication Standard requires suppliers and manufacturers to issue an MSDS for chemicals defined as "hazardous" by OSHA. Under normal conditions of use, RAUPEX pipe does not expose employees to potentially harmful chemicals. RAUPEX pipe meets the definition of articles in OSHA 29 CFR 1910.1200 and is exempt from the requirement to provide an MSDS.

4.1.8 Pipe Packaging, Handling and Storage

RAUPEX pipe coils are shipped in cardboard boxes to protect them from sunlight, rain, dirt and other hazards. Straight lengths of RAUPEX pipe are packaged and shipped in durable black polyethylene bags.

Keep pipe in the original packaging until it is required for installation. Return unused pipe to the packaging.

RAUPEX must be handled with care. Avoid the following:

- Dragging it over rough objects such as gravel or concrete
- Contact with oil or oily products such as gasoline and paint thinner
- Exposure to soldering or any open flame
- Excessive or permanent exposure to sunlight

4.1.9 Pipe Bending

RAUPEX pipe sizes up to 1 1/4 in. may be bent, even when cold. REHAU Support Bends make it fast and easy to create tight bends without kinking. The typical bend radius used by the installer is 8X the OD. The minimum bend radius is 5X the OD for cold bends. For an even smaller bend radius, the pipe may be heated with a hot air gun and bent to no less than 3X the OD. If a tighter bend radius is required, then the designer should consider using a smaller diameter pipe. Pipe bends are classified according to the centerline radius (CLR) of the bend as a ratio to the outer pipe diameter.

Note: A pipe may become kinked from excessive bending which may obstruct or reduce the flow. Kinked pipes may be repaired with a hot air gun.

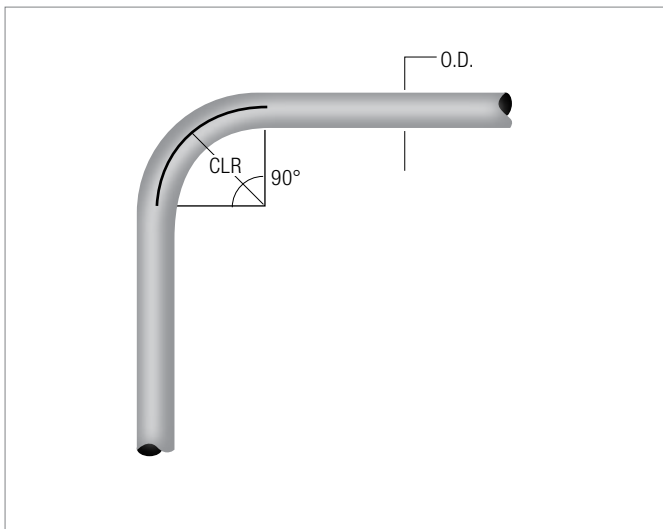

Fig. 4.3: Centerline radius (CLR) of RAUPEX pipe

4.1.10 Pipe Repair of Kinks

RAUPEX pipe is flexible and resists kinking even at temperatures well below freezing. Should the pipe become accidentally kinked, it is possible to restore the pipe to its original shape by removing any stress from the pipe and gently heating the pipe, taking care not to overheat and damage the surface of the pipe. Due to the memory effect, the pipe will return to its original shape.

Refer to the REHAU *Radiant Heating Installation Guide* for instructions on performing kink repairs.

4.1.11 Pipe Protection

Place pipe protection around RAUPEX pipe to prevent abrasion when passing through holes in the building's framework. Protection is not required for installation in wood studs, walls, floor plates or joists if the following provisions are met:

- The hole is at least 1/4 in (6 mm) larger than the outside diameter (OD) of the pipe
- The pipe is free to move for expansion and contraction
- The hole is clean (e.g., free of splinters, burrs, and rough edges)
- The hole has smooth, non-abrasive interior surface (e.g., bushing)

Note: To minimize noise associated with joist space installations, REHAU highly recommends use of pipe protection at all joist penetrations.

At concrete slab penetrations, RAUPEX pipes should be protected. Where RAUPEX pipe passes through holes in concrete, masonry or steel, pipe protection is always required.

Table 4.7: Bend Radius of RAUPEX Pipe

Bend Radius	Typical	Min. Cold	Min. Heated
	8X OD	5X OD	3X OD
Pipe Size	in (mm)	in (mm)	in (mm)
3/8 in	4.0 (102)	2.500 (64)	1.500 (38)
1/2 in	5.0 (127)	3.125 (79)	1.875 (48)
5/8 in	6.0 (152)	3.750 (95)	2.250 (57)
3/4 in	7.0 (178)	4.375 (111)	2.625 (67)
1 in	9.0 (229)	5.625 (143)	3.375 (86)
1 1/4 in	11.0 (279)	6.875 (175)	4.125 (105)

For RAUPEX pipe sizes 1 1/2 in. and greater, use elbow and other fittings to accomplish tight bends.

Table 4.8: RAUPEX Pipes With 100% Water

Flow Rate GPM	Flow Velocity								pressure loss in psi per 100 ft of RAUPEX pipe							
	ft/sec								100°F (38°C) Water							
	3/8"	1/2"	5/8"	3/4"	1"	1 1/4"	1 1/2"	2"	3/8"	1/2"	5/8"	3/4"	1"	1 1/4"	1 1/2"	2"
0.2	0.63	0.35	0.24	0.18	0.11	0.07	0.05	0.03	0.33	0.08	0.03	0.02	<.01	<.01	<.01	<.01
0.3	0.95	0.52	0.36	0.26	0.16	0.11	0.08	0.04	0.68	0.16	0.07	0.03	<.01	<.01	<.01	<.01
0.4	1.26	0.69	0.48	0.35	0.21	0.14	0.10	0.06	1.14	0.27	0.11	0.05	0.02	<.01	<.01	<.01
0.5	1.58	0.87	0.60	0.44	0.27	0.18	0.13	0.07	1.71	0.41	0.17	0.08	0.02	<.01	<.01	<.01
0.6	1.89	1.04	0.72	0.53	0.32	0.21	0.15	0.09	2.36	0.57	0.23	0.11	0.03	0.01	<.01	<.01
0.7	2.21	1.22	0.84	0.62	0.37	0.25	0.18	0.10	3.11	0.75	0.31	0.15	0.04	0.02	<.01	<.01
0.8	2.52	1.39	0.96	0.70	0.43	0.29	0.20	0.12	3.95	0.95	0.39	0.19	0.06	0.02	<.01	<.01
0.9	2.84	1.56	1.08	0.79	0.48	0.32	0.23	0.13	4.88	1.17	0.48	0.23	0.07	0.03	0.01	<.01
1.0	3.15	1.74	1.20	0.88	0.53	0.36	0.26	0.15	5.90	1.41	0.58	0.28	0.08	0.03	0.01	<.01
1.1	3.47	1.91	1.32	0.97	0.59	0.39	0.28	0.16	6.99	1.68	0.69	0.33	0.10	0.04	0.02	<.01
1.2	3.78	2.08	1.44	1.06	0.64	0.43	0.31	0.18	8.17	1.96	0.80	0.39	0.12	0.04	0.02	<.01
1.3	4.10	2.26	1.56	1.15	0.69	0.46	0.33	0.19	9.44	2.26	0.93	0.44	0.13	0.05	0.02	<.01
1.4	4.41	2.43	1.68	1.23	0.75	0.50	0.36	0.21	10.8	2.58	1.06	0.51	0.15	0.06	0.03	<.01
1.5	4.73	2.60	1.80	1.32	0.80	0.54	0.38	0.22	12.2	2.92	1.20	0.57	0.17	0.07	0.03	<.01
1.6	5.04	2.78	1.92	1.41	0.85	0.57	0.41	0.24	13.7	3.28	1.35	0.65	0.19	0.07	0.03	<.01
1.7	5.36	2.95	2.04	1.50	0.91	0.61	0.44	0.25	15.3	3.66	1.50	0.72	0.22	0.08	0.04	0.01
1.8	5.67	3.13	2.16	1.59	0.96	0.64	0.46	0.27	16.9	4.05	1.66	0.80	0.24	0.09	0.04	0.01
1.9	5.99	3.30	2.28	1.67	1.01	0.68	0.49	0.28	18.6	4.47	1.83	0.88	0.26	0.10	0.05	0.01
2.0	6.30	3.47	2.40	1.76	1.07	0.71	0.51	0.30	20.4	4.90	2.01	0.96	0.29	0.11	0.05	0.01
2.5	7.88	4.34	2.99	2.20	1.33	0.89	0.64	0.37	30.5	7.31	3.00	1.44	0.43	0.17	0.07	0.02
3.0	9.46	5.21	3.59	2.64	1.60	1.07	0.77	0.45	42.4	10.1	4.16	1.99	0.60	0.23	0.10	0.03
4.0		6.95	4.79	3.52	2.13	1.43	1.02	0.60		17.0	6.97	3.34	1.00	0.38	0.17	0.05
5.0		8.68	5.99	4.40	2.67	1.79	1.28	0.75		25.4	10.4	4.98	1.50	0.57	0.26	0.07
6.0		10.4	7.19	5.28	3.20	2.14	1.54	0.90		35.3	14.5	6.92	2.08	0.80	0.36	0.10
7.0			8.38	6.17	3.73	2.50	1.79	1.05			19.1	9.13	2.74	1.05	0.47	0.13
8.0			9.58	7.05	4.27	2.86	2.05	1.20			24.3	11.6	3.49	1.33	0.60	0.16
9.0			10.8	7.93	4.80	3.22	2.30	1.35			30.0	14.4	4.31	1.65	0.74	0.20
10.0				8.81	5.34	3.57	2.56	1.49				17.4	5.21	1.99	0.89	0.25
11.0				9.69	5.87	3.93	2.82	1.64				20.6	6.18	2.36	1.06	0.29
12.0				10.6	6.40	4.29	3.07	1.79				24.1	7.23	2.77	1.24	0.34
13.0					6.94	4.65	3.33	1.94					8.36	3.19	1.43	0.39
14.0					7.47	5.00	3.59	2.09					9.55	3.65	1.64	0.45
15.0					8.00	5.36	3.84	2.24					10.8	4.13	1.86	0.51
16.0					8.54	5.72	4.10	2.39					12.2	4.64	2.08	0.57
17.0					9.07	6.08	4.35	2.54					13.6	5.18	2.33	0.64
18.0					9.60	6.43	4.61	2.69					15.0	5.74	2.58	0.71
19.0					10.1	6.79	4.87	2.84					16.6	6.33	2.84	0.78
20.0					10.7	7.15	5.12	2.99					18.2	6.95	3.12	0.86
25.0						8.94	6.40	3.74						10.4	4.66	1.28
30.0						10.7	7.68	4.48						14.4	6.48	1.78
35.0							8.96	5.23							8.56	2.35
40.0							10.2	5.98							10.9	2.99
45.0								6.73								3.70
50.0								7.47								4.48
55.0								8.22								5.32
60.0								8.97								6.22
65.0								9.72								7.20
70.0								10.5								8.23
75.0								11.2								9.33

Flow Velocity above 8 feet per second may be considered excessive and may result in excessive pressure loss.

Shown is pressure loss in units of psi per 100 feet of pipe.

Example: for 200 lineal feet of pipe, double the value listed in this table.

Table 4.8: RAUPEX Pipe With 100% Water (continued)

Flow Rate GPM	pressure loss in psi per 100 ft of RAUPEX pipe															
	140°F (60°C) Water								180°F (82°C) Water							
	3/8"	1/2"	5/8"	3/4"	1"	1 1/4"	1 1/2"	2"	3/8"	1/2"	5/8"	3/4"	1"	1 1/4"	1 1/2"	2"
0.2	0.31	0.07	0.03	0.01	<.01	<.01	<.01	<.01	0.29	0.07	0.03	0.01	<.01	<.01	<.01	<.01
0.3	0.63	0.15	0.06	0.03	<.01	<.01	<.01	<.01	0.60	0.14	0.06	0.03	<.01	<.01	<.01	<.01
0.4	1.06	0.25	0.10	0.05	0.02	<.01	<.01	<.01	1.01	0.24	0.10	0.05	0.01	<.01	<.01	<.01
0.5	1.57	0.38	0.16	0.07	0.02	<.01	<.01	<.01	1.50	0.36	0.15	0.07	0.02	<.01	<.01	<.01
0.6	2.18	0.52	0.21	0.10	0.03	0.01	<.01	<.01	2.09	0.50	0.21	0.10	0.03	0.01	<.01	<.01
0.7	2.87	0.69	0.28	0.14	0.04	0.02	<.01	<.01	2.75	0.66	0.27	0.13	0.04	0.01	<.01	<.01
0.8	3.65	0.88	0.36	0.17	0.05	0.02	<.01	<.01	3.49	0.84	0.34	0.16	0.05	0.02	<.01	<.01
0.9	4.51	1.08	0.44	0.21	0.06	0.02	0.01	<.01	4.31	1.03	0.42	0.20	0.06	0.02	0.01	<.01
1.0	5.45	1.31	0.54	0.26	0.08	0.03	0.01	<.01	5.21	1.25	0.51	0.25	0.07	0.03	0.01	<.01
1.1	6.46	1.55	0.64	0.30	0.09	0.04	0.02	<.01	6.18	1.48	0.61	0.29	0.09	0.03	0.02	<.01
1.2	7.55	1.81	0.74	0.36	0.11	0.04	0.02	<.01	7.23	1.73	0.71	0.34	0.10	0.04	0.02	<.01
1.3	8.72	2.09	0.86	0.41	0.12	0.05	0.02	<.01	8.35	2.00	0.82	0.39	0.12	0.05	0.02	<.01
1.4	9.96	2.39	0.98	0.47	0.14	0.05	0.02	<.01	9.54	2.28	0.94	0.45	0.14	0.05	0.02	<.01
1.5	11.3	2.70	1.11	0.53	0.16	0.06	0.03	<.01	10.8	2.58	1.06	0.51	0.15	0.06	0.03	<.01
1.6	12.7	3.03	1.24	0.60	0.18	0.07	0.03	<.01	12.1	2.90	1.19	0.57	0.17	0.07	0.03	<.01
1.7	14.1	3.38	1.39	0.66	0.20	0.08	0.03	<.01	13.5	3.24	1.33	0.64	0.19	0.07	0.03	<.01
1.8	15.6	3.75	1.54	0.74	0.22	0.08	0.04	0.01	15.0	3.59	1.47	0.70	0.21	0.08	0.04	0.01
1.9	17.2	4.13	1.69	0.81	0.24	0.09	0.04	0.01	16.5	3.95	1.62	0.78	0.23	0.09	0.04	0.01
2.0	18.9	4.53	1.86	0.89	0.27	0.10	0.05	0.01	18.1	4.33	1.78	0.85	0.26	0.10	0.04	0.01
2.5	28.3	6.76	2.77	1.33	0.40	0.15	0.07	0.02	27.1	6.47	2.65	1.27	0.38	0.15	0.07	0.02
3.0	39.2	9.38	3.85	1.84	0.55	0.21	0.10	0.03	37.6	8.99	3.68	1.76	0.53	0.20	0.09	0.03
4.0		15.7	6.46	3.09	0.93	0.36	0.16	0.04		15.1	6.18	2.96	0.89	0.34	0.15	0.04
5.0		23.5	9.65	4.61	1.39	0.53	0.24	0.07		22.6	9.24	4.42	1.33	0.51	0.23	0.06
6.0		32.7	13.4	6.41	1.92	0.74	0.33	0.09		31.3	12.8	6.14	1.84	0.70	0.32	0.09
7.0			17.7	8.46	2.54	0.97	0.44	0.12			17.0	8.11	2.43	0.93	0.42	0.11
8.0			22.5	10.8	3.23	1.23	0.55	0.15			21.6	10.3	3.09	1.18	0.53	0.15
9.0			27.8	13.3	3.99	1.53	0.69	0.19			26.7	12.8	3.83	1.46	0.66	0.18
10.0				16.1	4.83	1.85	0.83	0.23				15.4	4.63	1.77	0.79	0.22
11.0				19.1	5.73	2.19	0.98	0.27				18.3	5.50	2.10	0.94	0.26
12.0				22.4	6.71	2.56	1.15	0.32				21.5	6.43	2.46	1.10	0.30
13.0					7.75	2.96	1.33	0.37					7.43	2.84	1.27	0.35
14.0					8.86	3.38	1.52	0.42					8.50	3.24	1.46	0.40
15.0					10.0	3.83	1.72	0.47					9.62	3.68	1.65	0.45
16.0					11.3	4.31	1.93	0.53					10.8	4.13	1.85	0.51
17.0					12.6	4.81	2.16	0.59					12.1	4.61	2.07	0.57
18.0					14.0	5.33	2.39	0.66					13.4	5.11	2.29	0.63
19.0					15.4	5.88	2.64	0.72					14.8	5.63	2.53	0.69
20.0					16.9	6.45	2.89	0.79					16.2	6.18	2.77	0.76
25.0						9.65	4.33	1.19						9.26	4.15	1.14
30.0						13.4	6.02	1.65						12.9	5.77	1.58
35.0							7.96	2.18							7.63	2.09
40.0								10.1	2.78						9.73	2.66
45.0									3.44							3.30
50.0									4.16							3.99
55.0									4.94							4.74
60.0									5.79							5.56
65.0									6.69							6.43
70.0									7.66							7.35
75.0									8.68							8.33

To express pressure loss in terms of feet of head, multiply the value listed by 2.307.

Example: 1 psi = 2.307 feet of head

Table 4.9: RAUPEX Pipe With 80% Water / 20% Propylene Glycol

Flow Rate GPM	Flow Velocity								pressure loss in psi per 100 ft of RAUPEX pipe							
	ft/sec								100°F (38°C) 20% Glycol							
	3/8"	1/2"	5/8"	3/4"	1"	1 1/4"	1 1/2"	2"	3/8"	1/2"	5/8"	3/4"	1"	1 1/4"	1 1/2"	2"
0.2	0.63	0.35	0.24	0.18	0.11	0.07	0.05	0.03	0.34	0.08	0.03	0.02	<.01	<.01	<.01	<.01
0.3	0.95	0.52	0.36	0.26	0.16	0.11	0.08	0.04	0.70	0.17	0.07	0.03	0.01	<.01	<.01	<.01
0.4	1.26	0.69	0.48	0.35	0.21	0.14	0.10	0.06	1.18	0.28	0.12	0.06	0.02	<.01	<.01	<.01
0.5	1.58	0.87	0.60	0.44	0.27	0.18	0.13	0.07	1.75	0.42	0.17	0.08	0.02	<.01	<.01	<.01
0.6	1.89	1.04	0.72	0.53	0.32	0.21	0.15	0.09	2.43	0.58	0.24	0.11	0.03	0.01	<.01	<.01
0.7	2.21	1.22	0.84	0.62	0.37	0.25	0.18	0.10	3.20	0.77	0.32	0.15	0.05	0.02	<.01	<.01
0.8	2.52	1.39	0.96	0.70	0.43	0.29	0.20	0.12	4.06	0.97	0.40	0.19	0.06	0.02	<.01	<.01
0.9	2.84	1.56	1.08	0.79	0.48	0.32	0.23	0.13	5.01	1.20	0.49	0.24	0.07	0.03	0.01	<.01
1.0	3.15	1.74	1.20	0.88	0.53	0.36	0.26	0.15	6.06	1.45	0.60	0.29	0.09	0.03	0.01	<.01
1.1	3.47	1.91	1.32	0.97	0.59	0.39	0.28	0.16	7.18	1.72	0.71	0.34	0.10	0.04	0.02	<.01
1.2	3.78	2.08	1.44	1.06	0.64	0.43	0.31	0.18	8.40	2.01	0.83	0.40	0.12	0.05	0.02	<.01
1.3	4.10	2.26	1.56	1.15	0.69	0.46	0.33	0.19	9.69	2.32	0.95	0.46	0.14	0.05	0.02	<.01
1.4	4.41	2.43	1.68	1.23	0.75	0.50	0.36	0.21	11.1	2.65	1.09	0.52	0.16	0.06	0.03	<.01
1.5	4.73	2.60	1.80	1.32	0.80	0.54	0.38	0.22	12.5	3.00	1.23	0.59	0.18	0.07	0.03	<.01
1.6	5.04	2.78	1.92	1.41	0.85	0.57	0.41	0.24	14.1	3.37	1.38	0.66	0.20	0.08	0.03	<.01
1.7	5.36	2.95	2.04	1.50	0.91	0.61	0.44	0.25	15.7	3.76	1.54	0.74	0.22	0.09	0.04	0.01
1.8	5.67	3.13	2.16	1.59	0.96	0.64	0.46	0.27	17.4	4.16	1.71	0.82	0.25	0.09	0.04	0.01
1.9	5.99	3.30	2.28	1.67	1.01	0.68	0.49	0.28	19.1	4.59	1.88	0.90	0.27	0.10	0.05	0.01
2.0	6.30	3.47	2.40	1.76	1.07	0.71	0.51	0.30	21.0	5.03	2.06	0.99	0.30	0.11	0.05	0.01
2.5	7.88	4.34	2.99	2.20	1.33	0.89	0.64	0.37	31.4	7.51	3.08	1.47	0.44	0.17	0.08	0.02
3.0	9.46	5.21	3.59	2.64	1.60	1.07	0.77	0.45	43.5	10.4	4.27	2.05	0.62	0.24	0.11	0.03
4.0		6.95	4.79	3.52	2.13	1.43	1.02	0.60		17.5	7.16	3.43	1.03	0.39	0.18	0.05
5.0		8.68	5.99	4.40	2.67	1.79	1.28	0.75		26.1	10.7	5.12	1.54	0.59	0.26	0.07
6.0		10.4	7.19	5.28	3.20	2.14	1.54	0.90		36.2	14.9	7.11	2.13	0.82	0.37	0.10
7.0			8.38	6.17	3.73	2.50	1.79	1.05		19.6	9.38	2.82	1.08	0.48	0.13	
8.0			9.58	7.05	4.27	2.86	2.05	1.20		24.9	11.9	3.58	1.37	0.62	0.17	
9.0			10.8	7.93	4.80	3.22	2.30	1.35		30.8	14.7	4.43	1.69	0.76	0.21	
10.0				8.81	5.34	3.57	2.56	1.49		17.8	5.35	2.05	0.92	0.25		
11.0				9.69	5.87	3.93	2.82	1.64		21.2	6.35	2.43	1.09	0.30		
12.0				10.6	6.40	4.29	3.07	1.79		24.8	7.43	2.84	1.28	0.35		
13.0					6.94	4.65	3.33	1.94		8.58	3.28	1.47	0.41			
14.0					7.47	5.00	3.59	2.09		9.81	3.75	1.68	0.46			
15.0					8.00	5.36	3.84	2.24		11.1	4.25	1.91	0.52			
16.0					8.54	5.72	4.10	2.39		12.5	4.77	2.14	0.59			
17.0					9.07	6.08	4.35	2.54		13.9	5.32	2.39	0.66			
18.0					9.60	6.43	4.61	2.69		15.4	5.90	2.65	0.73			
19.0					10.1	6.79	4.87	2.84		17.0	6.50	2.92	0.80			
20.0					10.7	7.15	5.12	2.99		18.7	7.14	3.20	0.88			
25.0						8.94	6.40	3.74			10.7	4.79	1.31			
30.0						10.7	7.68	4.48			14.8	6.66	1.83			
35.0							8.96	5.23				8.80	2.41			
40.0							10.2	5.98				11.2	3.07			
45.0								6.73					3.80			
50.0								7.47					4.60			
55.0								8.22					5.46			
60.0								8.97					6.39			
65.0								9.72					7.39			
70.0								10.5					8.45			
75.0								11.2					9.58			

Flow Velocity above 8 feet per second may be considered excessive and may result in excessive pressure loss.

Shown is pressure loss in units of psi per 100 feet of pipe.

Example: for 200 lineal feet of pipe, double the value listed in this table.

Table 4.9: RAUPEX Pipe With 80% Water / 20% Propylene Glycol (continued)

Flow Rate GPM	pressure loss in psi per 100 ft of RAUPEX pipe															
	140°F (60°C) 20% Glycol								180°F (82°C) 20% Glycol							
	3/8"	1/2"	5/8"	3/4"	1"	1 1/4"	1 1/2"	2"	3/8"	1/2"	5/8"	3/4"	1"	1 1/4"	1 1/2"	2"
0.2	0.31	0.08	0.03	0.01	<.01	<.01	<.01	<.01	0.30	0.07	0.03	0.01	<.01	<.01	<.01	<.01
0.3	0.65	0.16	0.06	0.03	<.01	<.01	<.01	<.01	0.62	0.15	0.06	0.03	<.01	<.01	<.01	<.01
0.4	1.08	0.26	0.11	0.05	0.02	<.01	<.01	<.01	1.03	0.25	0.10	0.05	0.01	<.01	<.01	<.01
0.5	1.61	0.39	0.16	0.08	0.02	<.01	<.01	<.01	1.54	0.37	0.15	0.07	0.02	<.01	<.01	<.01
0.6	2.24	0.54	0.22	0.11	0.03	0.01	<.01	<.01	2.13	0.51	0.21	0.10	0.03	0.01	<.01	<.01
0.7	2.95	0.71	0.29	0.14	0.04	0.02	<.01	<.01	2.81	0.67	0.28	0.13	0.04	0.02	<.01	<.01
0.8	3.74	0.90	0.37	0.18	0.05	0.02	<.01	<.01	3.57	0.86	0.35	0.17	0.05	0.02	<.01	<.01
0.9	4.62	1.11	0.46	0.22	0.07	0.03	0.01	<.01	4.42	1.06	0.43	0.21	0.06	0.02	0.01	<.01
1.0	5.59	1.34	0.55	0.26	0.08	0.03	0.01	<.01	5.33	1.28	0.52	0.25	0.08	0.03	0.01	<.01
1.1	6.63	1.59	0.65	0.31	0.09	0.04	0.02	<.01	6.33	1.52	0.62	0.30	0.09	0.03	0.02	<.01
1.2	7.75	1.86	0.76	0.37	0.11	0.04	0.02	<.01	7.40	1.77	0.73	0.35	0.10	0.04	0.02	<.01
1.3	8.95	2.14	0.88	0.42	0.13	0.05	0.02	<.01	8.54	2.05	0.84	0.40	0.12	0.05	0.02	<.01
1.4	10.2	2.45	1.00	0.48	0.14	0.06	0.02	<.01	9.76	2.34	0.96	0.46	0.14	0.05	0.02	<.01
1.5	11.6	2.77	1.14	0.54	0.16	0.06	0.03	<.01	11.0	2.65	1.09	0.52	0.16	0.06	0.03	<.01
1.6	13.0	3.11	1.28	0.61	0.18	0.07	0.03	<.01	12.4	2.97	1.22	0.58	0.18	0.07	0.03	<.01
1.7	14.5	3.47	1.42	0.68	0.20	0.08	0.04	<.01	13.8	3.31	1.36	0.65	0.20	0.07	0.03	<.01
1.8	16.0	3.84	1.58	0.75	0.23	0.09	0.04	0.01	15.3	3.67	1.51	0.72	0.22	0.08	0.04	0.01
1.9	17.7	4.23	1.74	0.83	0.25	0.10	0.04	0.01	16.9	4.04	1.66	0.79	0.24	0.09	0.04	0.01
2.0	19.4	4.64	1.91	0.91	0.27	0.11	0.05	0.01	18.5	4.43	1.82	0.87	0.26	0.10	0.05	0.01
2.5	29.0	6.93	2.84	1.36	0.41	0.16	0.07	0.02	27.7	6.62	2.72	1.30	0.39	0.15	0.07	0.02
3.0	40.2	9.62	3.95	1.89	0.57	0.22	0.10	0.03	38.5	9.20	3.77	1.80	0.54	0.21	0.09	0.03
4.0		16.2	6.62	3.17	0.95	0.36	0.16	0.05		15.4	6.33	3.03	0.91	0.35	0.16	0.04
5.0		24.1	9.90	4.73	1.42	0.54	0.24	0.07		23.1	9.46	4.52	1.36	0.52	0.23	0.06
6.0		33.5	13.7	6.57	1.97	0.75	0.34	0.09		32.1	13.1	6.28	1.89	0.72	0.32	0.09
7.0			18.1	8.68	2.60	1.00	0.45	0.12			17.4	8.30	2.49	0.95	0.43	0.12
8.0			23.1	11.0	3.31	1.27	0.57	0.16			22.1	10.6	3.17	1.21	0.54	0.15
9.0			28.6	13.7	4.09	1.57	0.70	0.19			27.3	13.1	3.92	1.50	0.67	0.18
10.0				16.5	4.95	1.89	0.85	0.23				15.8	4.74	1.81	0.81	0.22
11.0				19.6	5.88	2.25	1.01	0.28				18.8	5.62	2.15	0.96	0.26
12.0				22.9	6.88	2.63	1.18	0.32				22.0	6.58	2.51	1.13	0.31
13.0					7.95	3.04	1.36	0.37					7.60	2.90	1.30	0.36
14.0					9.09	3.47	1.56	0.43					8.69	3.32	1.49	0.41
15.0					10.3	3.93	1.76	0.48					9.85	3.76	1.69	0.46
16.0					11.6	4.42	1.98	0.54					11.1	4.23	1.90	0.52
17.0					12.9	4.93	2.21	0.61					12.4	4.72	2.12	0.58
18.0					14.3	5.47	2.45	0.67					13.7	5.23	2.35	0.64
19.0					15.8	6.03	2.70	0.74					15.1	5.77	2.59	0.71
20.0					17.3	6.61	2.97	0.81					16.6	6.33	2.84	0.78
25.0						9.90	4.44	1.22						9.48	4.25	1.16
30.0						13.8	6.17	1.69						13.2	5.91	1.62
35.0							8.16	2.24							7.81	2.14
40.0							10.4	2.85							9.95	2.73
45.0								3.52								3.37
50.0								4.27								4.09
55.0								5.07								4.86
60.0								5.94								5.69
65.0								6.86								6.58
70.0								7.85								7.52
75.0								8.90								8.53

To express pressure loss in terms of feet of head, multiply the value listed by 2.307.

Example: 1 psi = 2.307 feet of head

Table 4.10: RAUPEX Pipe With 70% Water / 30% Propylene Glycol

Flow Rate GPM	Flow Velocity								pressure loss in psi per 100 ft of RAUPEX pipe							
	ft/sec								100°F (38°C) 30% Glycol							
	3/8"	1/2"	5/8"	3/4"	1"	1 1/4"	1 1/2"	2"	3/8"	1/2"	5/8"	3/4"	1"	1 1/4"	1 1/2"	2"
0.2	0.63	0.35	0.24	0.18	0.11	0.07	0.05	0.03	0.35	0.08	0.03	0.02	<.01	<.01	<.01	<.01
0.3	0.95	0.52	0.36	0.26	0.16	0.11	0.08	0.04	0.71	0.17	0.07	0.03	0.01	<.01	<.01	<.01
0.4	1.26	0.69	0.48	0.35	0.21	0.14	0.10	0.06	1.19	0.29	0.12	0.06	0.02	<.01	<.01	<.01
0.5	1.58	0.87	0.60	0.44	0.27	0.18	0.13	0.07	1.77	0.43	0.17	0.08	0.03	<.01	<.01	<.01
0.6	1.89	1.04	0.72	0.53	0.32	0.21	0.15	0.09	2.46	0.59	0.24	0.12	0.03	0.01	<.01	<.01
0.7	2.21	1.22	0.84	0.62	0.37	0.25	0.18	0.10	3.23	0.78	0.32	0.15	0.05	0.02	<.01	<.01
0.8	2.52	1.39	0.96	0.70	0.43	0.29	0.20	0.12	4.11	0.99	0.40	0.19	0.06	0.02	0.01	<.01
0.9	2.84	1.56	1.08	0.79	0.48	0.32	0.23	0.13	5.07	1.22	0.50	0.24	0.07	0.03	0.01	<.01
1.0	3.15	1.74	1.20	0.88	0.53	0.36	0.26	0.15	6.13	1.47	0.60	0.29	0.09	0.03	0.02	<.01
1.1	3.47	1.91	1.32	0.97	0.59	0.39	0.28	0.16	7.27	1.74	0.72	0.34	0.10	0.04	0.02	<.01
1.2	3.78	2.08	1.44	1.06	0.64	0.43	0.31	0.18	8.49	2.04	0.84	0.40	0.12	0.05	0.02	<.01
1.3	4.10	2.26	1.56	1.15	0.69	0.46	0.33	0.19	9.80	2.35	0.97	0.46	0.14	0.05	0.02	<.01
1.4	4.41	2.43	1.68	1.23	0.75	0.50	0.36	0.21	11.2	2.68	1.10	0.53	0.16	0.06	0.03	<.01
1.5	4.73	2.60	1.80	1.32	0.80	0.54	0.38	0.22	12.7	3.04	1.25	0.60	0.18	0.07	0.03	<.01
1.6	5.04	2.78	1.92	1.41	0.85	0.57	0.41	0.24	14.2	3.41	1.40	0.67	0.20	0.08	0.03	<.01
1.7	5.36	2.95	2.04	1.50	0.91	0.61	0.44	0.25	15.9	3.80	1.56	0.75	0.22	0.09	0.04	0.01
1.8	5.67	3.13	2.16	1.59	0.96	0.64	0.46	0.27	17.6	4.21	1.73	0.83	0.25	0.10	0.04	0.01
1.9	5.99	3.30	2.28	1.67	1.01	0.68	0.49	0.28	19.4	4.64	1.90	0.91	0.27	0.11	0.05	0.01
2.0	6.30	3.47	2.40	1.76	1.07	0.71	0.51	0.30	21.2	5.09	2.09	1.00	0.30	0.12	0.05	0.01
2.5	7.88	4.34	2.99	2.20	1.33	0.89	0.64	0.37	31.7	7.59	3.12	1.49	0.45	0.17	0.08	0.02
3.0	9.46	5.21	3.59	2.64	1.60	1.07	0.77	0.45	44.0	10.5	4.32	2.07	0.62	0.24	0.11	0.03
4.0		6.95	4.79	3.52	2.13	1.43	1.02	0.60		17.7	7.25	3.47	1.04	0.40	0.18	0.05
5.0		8.68	5.99	4.40	2.67	1.79	1.28	0.75		26.4	10.8	5.18	1.56	0.60	0.27	0.07
6.0		10.4	7.19	5.28	3.20	2.14	1.54	0.90		36.7	15.0	7.19	2.16	0.83	0.37	0.10
7.0			8.38	6.17	3.73	2.50	1.79	1.05			19.8	9.48	2.85	1.09	0.49	0.13
8.0			9.58	7.05	4.27	2.86	2.05	1.20			25.2	12.1	3.62	1.39	0.62	0.17
9.0			10.8	7.93	4.80	3.22	2.30	1.35			31.2	14.9	4.48	1.71	0.77	0.21
10.0				8.81	5.34	3.57	2.56	1.49			18.0	5.41	2.07	0.93	0.26	
11.0				9.69	5.87	3.93	2.82	1.64			21.4	6.43	2.46	1.10	0.30	
12.0				10.6	6.40	4.29	3.07	1.79			25.1	7.52	2.87	1.29	0.35	
13.0					6.94	4.65	3.33	1.94				8.68	3.32	1.49	0.41	
14.0					7.47	5.00	3.59	2.09				9.92	3.79	1.70	0.47	
15.0					8.00	5.36	3.84	2.24				11.2	4.30	1.93	0.53	
16.0					8.54	5.72	4.10	2.39				12.6	4.83	2.17	0.60	
17.0					9.07	6.08	4.35	2.54				14.1	5.38	2.42	0.66	
18.0					9.60	6.43	4.61	2.69				15.6	5.97	2.68	0.74	
19.0					10.1	6.79	4.87	2.84				17.2	6.58	2.95	0.81	
20.0					10.7	7.15	5.12	2.99				18.9	7.22	3.24	0.89	
25.0						8.94	6.40	3.74					10.8	4.84	1.33	
30.0						10.7	7.68	4.48					15.0	6.73	1.85	
35.0							8.96	5.23						8.90	2.44	
40.0							10.2	5.98						11.3	3.11	
45.0								6.73								3.84
50.0								7.47								4.65
55.0								8.22								5.53
60.0								8.97								6.47
65.0								9.72								7.48
70.0								10.5								8.55
75.0								11.2								9.69

Flow Velocity above 8 feet per second may be considered excessive and may result in excessive pressure loss.

Shown is pressure loss in units of psi per 100 feet of pipe.

Example: for 200 lineal feet of pipe, double the value listed in this table.

Table 4.10: RAUPEX Pipe With 70% Water / 30% Propylene Glycol (continued)

Flow Rate GPM	pressure loss in psi per 100 ft of RAUPEX pipe															
	140°F (60°C) 30% Glycol								180°F (82°C) 30% Glycol							
	3/8"	1/2"	5/8"	3/4"	1"	1 1/4"	1 1/2"	2"	3/8"	1/2"	5/8"	3/4"	1"	1 1/4"	1 1/2"	2"
0.2	0.32	0.08	0.03	0.02	<.01	<.01	<.01	<.01	0.30	0.07	0.03	0.01	<.01	<.01	<.01	<.01
0.3	0.65	0.16	0.06	0.03	<.01	<.01	<.01	<.01	0.62	0.15	0.06	0.03	<.01	<.01	<.01	<.01
0.4	1.09	0.26	0.11	0.05	0.02	<.01	<.01	<.01	1.04	0.25	0.10	0.05	0.01	<.01	<.01	<.01
0.5	1.63	0.39	0.16	0.08	0.02	<.01	<.01	<.01	1.55	0.37	0.15	0.07	0.02	<.01	<.01	<.01
0.6	2.26	0.54	0.22	0.11	0.03	0.01	<.01	<.01	2.15	0.52	0.21	0.10	0.03	0.01	<.01	<.01
0.7	2.98	0.71	0.29	0.14	0.04	0.02	<.01	<.01	2.84	0.68	0.28	0.13	0.04	0.02	<.01	<.01
0.8	3.78	0.91	0.37	0.18	0.05	0.02	<.01	<.01	3.61	0.86	0.36	0.17	0.05	0.02	<.01	<.01
0.9	4.67	1.12	0.46	0.22	0.07	0.03	0.01	<.01	4.46	1.07	0.44	0.21	0.06	0.02	0.01	<.01
1.0	5.64	1.35	0.56	0.27	0.08	0.03	0.01	<.01	5.38	1.29	0.53	0.25	0.08	0.03	0.01	<.01
1.1	6.70	1.60	0.66	0.32	0.10	0.04	0.02	<.01	6.39	1.53	0.63	0.30	0.09	0.03	0.02	<.01
1.2	7.83	1.88	0.77	0.37	0.11	0.04	0.02	<.01	7.47	1.79	0.73	0.35	0.11	0.04	0.02	<.01
1.3	9.04	2.17	0.89	0.43	0.13	0.05	0.02	<.01	8.62	2.07	0.85	0.41	0.12	0.05	0.02	<.01
1.4	10.3	2.47	1.02	0.49	0.15	0.06	0.03	<.01	9.85	2.36	0.97	0.46	0.14	0.05	0.02	<.01
1.5	11.7	2.80	1.15	0.55	0.17	0.06	0.03	<.01	11.2	2.67	1.10	0.52	0.16	0.06	0.03	<.01
1.6	13.1	3.14	1.29	0.62	0.19	0.07	0.03	<.01	12.5	3.00	1.23	0.59	0.18	0.07	0.03	<.01
1.7	14.6	3.50	1.44	0.69	0.21	0.08	0.04	<.01	14.0	3.34	1.37	0.66	0.20	0.08	0.03	<.01
1.8	16.2	3.88	1.59	0.76	0.23	0.09	0.04	0.01	15.5	3.70	1.52	0.73	0.22	0.08	0.04	0.01
1.9	17.9	4.28	1.76	0.84	0.25	0.10	0.04	0.01	17.1	4.08	1.67	0.80	0.24	0.09	0.04	0.01
2.0	19.6	4.69	1.92	0.92	0.28	0.11	0.05	0.01	18.7	4.48	1.84	0.88	0.26	0.10	0.05	0.01
2.5	29.3	7.00	2.87	1.38	0.41	0.16	0.07	0.02	28.0	6.69	2.74	1.31	0.39	0.15	0.07	0.02
3.0	40.7	9.72	3.99	1.91	0.57	0.22	0.10	0.03	38.8	9.28	3.81	1.82	0.55	0.21	0.09	0.03
4.0		16.3	6.69	3.20	0.96	0.37	0.17	0.05		15.6	6.39	3.05	0.92	0.35	0.16	0.04
5.0		24.4	10.0	4.78	1.44	0.55	0.25	0.07		23.3	9.55	4.57	1.37	0.52	0.24	0.06
6.0		33.9	13.9	6.64	1.99	0.76	0.34	0.09		32.4	13.3	6.34	1.90	0.73	0.33	0.09
7.0			18.3	8.76	2.63	1.01	0.45	0.12			17.5	8.37	2.51	0.96	0.43	0.12
8.0			23.3	11.2	3.35	1.28	0.57	0.16			22.3	10.7	3.20	1.22	0.55	0.15
9.0			28.9	13.8	4.14	1.58	0.71	0.20			27.6	13.2	3.95	1.51	0.68	0.19
10.0				16.7	5.00	1.91	0.86	0.24				15.9	4.78	1.83	0.82	0.23
11.0				19.8	5.94	2.27	1.02	0.28				18.9	5.68	2.17	0.97	0.27
12.0				23.2	6.95	2.66	1.19	0.33				22.2	6.64	2.54	1.14	0.31
13.0					8.03	3.07	1.38	0.38					7.68	2.93	1.32	0.36
14.0					9.18	3.51	1.57	0.43					8.78	3.35	1.50	0.41
15.0					10.4	3.97	1.78	0.49					9.94	3.80	1.70	0.47
16.0					11.7	4.46	2.00	0.55					11.2	4.27	1.91	0.53
17.0					13.0	4.98	2.23	0.61					12.5	4.76	2.14	0.59
18.0					14.5	5.52	2.48	0.68					13.8	5.28	2.37	0.65
19.0					15.9	6.09	2.73	0.75					15.2	5.82	2.61	0.72
20.0					17.5	6.68	3.00	0.82					16.7	6.39	2.86	0.79
25.0						10.0	4.49	1.23						9.56	4.29	1.18
30.0						13.9	6.24	1.71						13.3	5.96	1.63
35.0							8.25	2.26							7.89	2.16
40.0							10.5	2.88							10.0	2.75
45.0								3.56								3.41
50.0								4.31								4.12
55.0								5.12								4.90
60.0								6.00								5.74
65.0								6.94								6.64
70.0								7.93								7.59
75.0								8.99								8.61

To express pressure loss in terms of feet of head, multiply the value listed by 2.307.
Example: 1 psi = 2.307 feet of head

Table 4.11: RAUPEX Pipe With 60% Water / 40% Propylene Glycol

Flow Rate GPM	Flow Velocity								pressure loss in psi per 100 ft of RAUPEX pipe							
	ft/sec								100°F (38°C) 40% Glycol							
	3/8"	1/2"	5/8"	3/4"	1"	1 1/4"	1 1/2"	2"	3/8"	1/2"	5/8"	3/4"	1"	1 1/4"	1 1/2"	2"
0.2	0.63	0.35	0.24	0.18	0.11	0.07	0.05	0.03	0.35	0.08	0.03	0.02	<.01	<.01	<.01	<.01
0.3	0.95	0.52	0.36	0.26	0.16	0.11	0.08	0.04	0.72	0.17	0.07	0.03	0.01	<.01	<.01	<.01
0.4	1.26	0.69	0.48	0.35	0.21	0.14	0.10	0.06	1.20	0.29	0.12	0.06	0.02	<.01	<.01	<.01
0.5	1.58	0.87	0.60	0.44	0.27	0.18	0.13	0.07	1.79	0.43	0.18	0.08	0.03	<.01	<.01	<.01
0.6	1.89	1.04	0.72	0.53	0.32	0.21	0.15	0.09	2.48	0.59	0.24	0.12	0.04	0.01	<.01	<.01
0.7	2.21	1.22	0.84	0.62	0.37	0.25	0.18	0.10	3.27	0.78	0.32	0.15	0.05	0.02	<.01	<.01
0.8	2.52	1.39	0.96	0.70	0.43	0.29	0.20	0.12	4.15	1.00	0.41	0.20	0.06	0.02	0.01	<.01
0.9	2.84	1.56	1.08	0.79	0.48	0.32	0.23	0.13	5.12	1.23	0.50	0.24	0.07	0.03	0.01	<.01
1.0	3.15	1.74	1.20	0.88	0.53	0.36	0.26	0.15	6.19	1.48	0.61	0.29	0.09	0.03	0.02	<.01
1.1	3.47	1.91	1.32	0.97	0.59	0.39	0.28	0.16	7.34	1.76	0.72	0.35	0.10	0.04	0.02	<.01
1.2	3.78	2.08	1.44	1.06	0.64	0.43	0.31	0.18	8.58	2.06	0.84	0.40	0.12	0.05	0.02	<.01
1.3	4.10	2.26	1.56	1.15	0.69	0.46	0.33	0.19	9.90	2.37	0.97	0.47	0.14	0.05	0.02	<.01
1.4	4.41	2.43	1.68	1.23	0.75	0.50	0.36	0.21	11.3	2.71	1.11	0.53	0.16	0.06	0.03	<.01
1.5	4.73	2.60	1.80	1.32	0.80	0.54	0.38	0.22	12.8	3.07	1.26	0.60	0.18	0.07	0.03	<.01
1.6	5.04	2.78	1.92	1.41	0.85	0.57	0.41	0.24	14.4	3.44	1.41	0.68	0.20	0.08	0.04	<.01
1.7	5.36	2.95	2.04	1.50	0.91	0.61	0.44	0.25	16.0	3.84	1.58	0.75	0.23	0.09	0.04	0.01
1.8	5.67	3.13	2.16	1.59	0.96	0.64	0.46	0.27	17.7	4.25	1.75	0.84	0.25	0.10	0.04	0.01
1.9	5.99	3.30	2.28	1.67	1.01	0.68	0.49	0.28	19.6	4.68	1.92	0.92	0.28	0.11	0.05	0.01
2.0	6.30	3.47	2.40	1.76	1.07	0.71	0.51	0.30	21.4	5.14	2.11	1.01	0.30	0.12	0.05	0.01
2.5	7.88	4.34	2.99	2.20	1.33	0.89	0.64	0.37	32.0	7.67	3.15	1.51	0.45	0.17	0.08	0.02
3.0	9.46	5.21	3.59	2.64	1.60	1.07	0.77	0.45	44.4	10.6	4.36	2.09	0.63	0.24	0.11	0.03
4.0		6.95	4.79	3.52	2.13	1.43	1.02	0.60		17.8	7.32	3.50	1.05	0.40	0.18	0.05
5.0		8.68	5.99	4.40	2.67	1.79	1.28	0.75		26.7	10.9	5.23	1.57	0.60	0.27	0.07
6.0		10.4	7.19	5.28	3.20	2.14	1.54	0.90		37.0	15.2	7.26	2.18	0.83	0.37	0.10
7.0			8.38	6.17	3.73	2.50	1.79	1.05			20.0	9.58	2.88	1.10	0.49	0.14
8.0			9.58	7.05	4.27	2.86	2.05	1.20			25.5	12.2	3.66	1.40	0.63	0.17
9.0			10.8	7.93	4.80	3.22	2.30	1.35			31.5	15.1	4.52	1.73	0.78	0.21
10.0				8.81	5.34	3.57	2.56	1.49			18.2	5.46	2.09	0.94	0.26	
11.0				9.69	5.87	3.93	2.82	1.64			21.6	6.49	2.48	1.11	0.31	
12.0				10.6	6.40	4.29	3.07	1.79			25.3	7.59	2.90	1.30	0.36	
13.0					6.94	4.65	3.33	1.94				8.77	3.35	1.50	0.41	
14.0					7.47	5.00	3.59	2.09				10.0	3.83	1.72	0.47	
15.0					8.00	5.36	3.84	2.24				11.3	4.34	1.95	0.54	
16.0					8.54	5.72	4.10	2.39				12.7	4.87	2.19	0.60	
17.0					9.07	6.08	4.35	2.54				14.2	5.43	2.44	0.67	
18.0					9.60	6.43	4.61	2.69				15.8	6.03	2.70	0.74	
19.0					10.1	6.79	4.87	2.84				17.4	6.64	2.98	0.82	
20.0					10.7	7.15	5.12	2.99				19.1	7.29	3.27	0.90	
25.0						8.94	6.40	3.74					10.9	4.89	1.34	
30.0						10.7	7.68	4.48					15.2	6.80	1.87	
35.0							8.96	5.23						8.98	2.46	
40.0							10.2	5.98						11.4	3.14	
45.0								6.73							3.88	
50.0								7.47							4.70	
55.0								8.22							5.58	
60.0								8.97							6.53	
65.0								9.72							7.55	
70.0								10.5							8.63	
75.0								11.2							9.78	

Flow Velocity above 8 feet per second may be considered excessive and may result in excessive pressure loss.

Shown is pressure loss in units of psi per 100 feet of pipe.

Example: for 200 lineal feet of pipe, double the value listed in this table.

Table 4.11: RAUPEX Pipe With 60% Water / 40% Propylene Glycol (continued)

Flow Rate GPM	pressure loss in psi per 100 ft of RAUPEX pipe															
	140°F (60°C) 40% Glycol								180°F (82°C) 40% Glycol							
	3/8"	1/2"	5/8"	3/4"	1"	1 1/4"	1 1/2"	2"	3/8"	1/2"	5/8"	3/4"	1"	1 1/4"	1 1/2"	2"
0.2	0.32	0.08	0.03	0.02	<.01	<.01	<.01	<.01	0.30	0.07	0.03	0.01	<.01	<.01	<.01	<.01
0.3	0.66	0.16	0.07	0.03	<.01	<.01	<.01	<.01	0.63	0.15	0.06	0.03	<.01	<.01	<.01	<.01
0.4	1.10	0.26	0.11	0.05	0.02	<.01	<.01	<.01	1.05	0.25	0.10	0.05	0.01	<.01	<.01	<.01
0.5	1.64	0.39	0.16	0.08	0.02	<.01	<.01	<.01	1.57	0.38	0.15	0.07	0.02	<.01	<.01	<.01
0.6	2.28	0.55	0.22	0.11	0.03	0.01	<.01	<.01	2.17	0.52	0.21	0.10	0.03	0.01	<.01	<.01
0.7	3.00	0.72	0.30	0.14	0.04	0.02	<.01	<.01	2.86	0.69	0.28	0.14	0.04	0.02	<.01	<.01
0.8	3.82	0.91	0.38	0.18	0.05	0.02	<.01	<.01	3.64	0.87	0.36	0.17	0.05	0.02	<.01	<.01
0.9	4.71	1.13	0.46	0.22	0.07	0.03	0.01	<.01	4.49	1.08	0.44	0.21	0.06	0.02	0.01	<.01
1.0	5.69	1.36	0.56	0.27	0.08	0.03	0.01	<.01	5.43	1.30	0.53	0.26	0.08	0.03	0.01	<.01
1.1	6.75	1.62	0.66	0.32	0.10	0.04	0.02	<.01	6.44	1.54	0.63	0.30	0.09	0.03	0.02	<.01
1.2	7.90	1.89	0.78	0.37	0.11	0.04	0.02	<.01	7.53	1.80	0.74	0.35	0.11	0.04	0.02	<.01
1.3	9.12	2.18	0.90	0.43	0.13	0.05	0.02	<.01	8.69	2.08	0.85	0.41	0.12	0.05	0.02	<.01
1.4	10.4	2.49	1.02	0.49	0.15	0.06	0.03	<.01	9.93	2.38	0.98	0.47	0.14	0.05	0.02	<.01
1.5	11.8	2.82	1.16	0.55	0.17	0.06	0.03	<.01	11.2	2.69	1.10	0.53	0.16	0.06	0.03	<.01
1.6	13.2	3.17	1.30	0.62	0.19	0.07	0.03	<.01	12.6	3.02	1.24	0.59	0.18	0.07	0.03	<.01
1.7	14.8	3.53	1.45	0.69	0.21	0.08	0.04	<.01	14.1	3.37	1.38	0.66	0.20	0.08	0.03	<.01
1.8	16.4	3.92	1.61	0.77	0.23	0.09	0.04	0.01	15.6	3.73	1.53	0.73	0.22	0.08	0.04	0.01
1.9	18.0	4.31	1.77	0.85	0.25	0.10	0.04	0.01	17.2	4.11	1.69	0.81	0.24	0.09	0.04	0.01
2.0	19.8	4.73	1.94	0.93	0.28	0.11	0.05	0.01	18.9	4.51	1.85	0.89	0.27	0.10	0.05	0.01
2.5	29.5	7.07	2.90	1.39	0.42	0.16	0.07	0.02	28.2	6.74	2.76	1.32	0.40	0.15	0.07	0.02
3.0	41.0	9.81	4.02	1.92	0.58	0.22	0.10	0.03	39.1	9.35	3.84	1.84	0.55	0.21	0.09	0.03
4.0		16.5	6.75	3.23	0.97	0.37	0.17	0.05		15.7	6.44	3.08	0.92	0.35	0.16	0.04
5.0		24.6	10.1	4.82	1.45	0.55	0.25	0.07		23.5	9.62	4.60	1.38	0.53	0.24	0.07
6.0		34.2	14.0	6.70	2.01	0.77	0.35	0.10		32.6	13.4	6.39	1.92	0.73	0.33	0.09
7.0			18.5	8.84	2.65	1.01	0.46	0.13			17.7	8.44	2.53	0.97	0.43	0.12
8.0			23.5	11.2	3.37	1.29	0.58	0.16			22.5	10.7	3.22	1.23	0.55	0.15
9.0			29.1	13.9	4.17	1.60	0.72	0.20			27.8	13.3	3.98	1.52	0.68	0.19
10.0				16.8	5.05	1.93	0.87	0.24				16.1	4.82	1.84	0.83	0.23
11.0				20.0	5.99	2.29	1.03	0.28				19.1	5.72	2.19	0.98	0.27
12.0				23.4	7.01	2.68	1.20	0.33				22.3	6.69	2.56	1.15	0.32
13.0					8.10	3.10	1.39	0.38					7.74	2.95	1.33	0.36
14.0					9.26	3.54	1.59	0.44					8.84	3.38	1.52	0.42
15.0					10.5	4.01	1.80	0.49					10.02	3.83	1.72	0.47
16.0					11.8	4.50	2.02	0.55					11.3	4.30	1.93	0.53
17.0					13.2	5.02	2.25	0.62					12.6	4.80	2.15	0.59
18.0					14.6	5.57	2.50	0.69					13.9	5.32	2.39	0.65
19.0					16.1	6.14	2.76	0.76					15.4	5.87	2.63	0.72
20.0					17.6	6.74	3.02	0.83					16.9	6.44	2.89	0.79
25.0						10.1	4.52	1.24						9.64	4.32	1.18
30.0						14.0	6.29	1.72						13.4	6.01	1.65
35.0							8.32	2.28							7.95	2.18
40.0							10.6	2.90							10.1	2.77
45.0								3.59								3.43
50.0								4.35								4.16
55.0								5.17								4.94
60.0								6.05								5.78
65.0								7.00								6.69
70.0								8.00								7.65
75.0								9.07								8.68

To express pressure loss in terms of feet of head, multiply the value listed by 2.307.
Example: 1 psi = 2.307 feet of head

Table 4.12: RAUPEX Pipe With 50% Water / 50% Propylene Glycol

Flow Rate GPM	Flow Velocity								pressure loss in psi per 100 ft of RAUPEX pipe							
	ft/sec								100°F (38°C) 50% Glycol							
	3/8"	1/2"	5/8"	3/4"	1"	1 1/4"	1 1/2"	2"	3/8"	1/2"	5/8"	3/4"	1"	1 1/4"	1 1/2"	2"
0.2	0.63	0.35	0.24	0.18	0.11	0.07	0.05	0.03	0.35	0.08	0.03	0.02	<.01	<.01	<.01	<.01
0.3	0.95	0.52	0.36	0.26	0.16	0.11	0.08	0.04	0.72	0.17	0.07	0.03	0.01	<.01	<.01	<.01
0.4	1.26	0.69	0.48	0.35	0.21	0.14	0.10	0.06	1.21	0.29	0.12	0.06	0.02	<.01	<.01	<.01
0.5	1.58	0.87	0.60	0.44	0.27	0.18	0.13	0.07	1.80	0.43	0.18	0.09	0.03	<.01	<.01	<.01
0.6	1.89	1.04	0.72	0.53	0.32	0.21	0.15	0.09	2.50	0.60	0.25	0.12	0.04	0.01	<.01	<.01
0.7	2.21	1.22	0.84	0.62	0.37	0.25	0.18	0.10	3.29	0.79	0.32	0.16	0.05	0.02	<.01	<.01
0.8	2.52	1.39	0.96	0.70	0.43	0.29	0.20	0.12	4.18	1.00	0.41	0.20	0.06	0.02	0.01	<.01
0.9	2.84	1.56	1.08	0.79	0.48	0.32	0.23	0.13	5.16	1.24	0.51	0.24	0.07	0.03	0.01	<.01
1.0	3.15	1.74	1.20	0.88	0.53	0.36	0.26	0.15	6.24	1.50	0.61	0.29	0.09	0.03	0.02	<.01
1.1	3.47	1.91	1.32	0.97	0.59	0.39	0.28	0.16	7.40	1.77	0.73	0.35	0.11	0.04	0.02	<.01
1.2	3.78	2.08	1.44	1.06	0.64	0.43	0.31	0.18	8.64	2.07	0.85	0.41	0.12	0.05	0.02	<.01
1.3	4.10	2.26	1.56	1.15	0.69	0.46	0.33	0.19	9.98	2.39	0.98	0.47	0.14	0.05	0.02	<.01
1.4	4.41	2.43	1.68	1.23	0.75	0.50	0.36	0.21	11.4	2.73	1.12	0.54	0.16	0.06	0.03	<.01
1.5	4.73	2.60	1.80	1.32	0.80	0.54	0.38	0.22	12.9	3.09	1.27	0.61	0.18	0.07	0.03	<.01
1.6	5.04	2.78	1.92	1.41	0.85	0.57	0.41	0.24	14.5	3.47	1.42	0.68	0.21	0.08	0.04	<.01
1.7	5.36	2.95	2.04	1.50	0.91	0.61	0.44	0.25	16.1	3.87	1.59	0.76	0.23	0.09	0.04	0.01
1.8	5.67	3.13	2.16	1.59	0.96	0.64	0.46	0.27	17.9	4.29	1.76	0.84	0.25	0.10	0.04	0.01
1.9	5.99	3.30	2.28	1.67	1.01	0.68	0.49	0.28	19.7	4.72	1.94	0.93	0.28	0.11	0.05	0.01
2.0	6.30	3.47	2.40	1.76	1.07	0.71	0.51	0.30	21.6	5.18	2.13	1.02	0.31	0.12	0.05	0.01
2.5	7.88	4.34	2.99	2.20	1.33	0.89	0.64	0.37	32.3	7.73	3.17	1.52	0.46	0.17	0.08	0.02
3.0	9.46	5.21	3.59	2.64	1.60	1.07	0.77	0.45	44.8	10.7	4.40	2.11	0.63	0.24	0.11	0.03
4.0		6.95	4.79	3.52	2.13	1.43	1.02	0.60		18.0	7.38	3.53	1.06	0.41	0.18	0.05
5.0		8.68	5.99	4.40	2.67	1.79	1.28	0.75		26.9	11.0	5.27	1.58	0.61	0.27	0.08
6.0		10.4	7.19	5.28	3.20	2.14	1.54	0.90		37.3	15.3	7.32	2.20	0.84	0.38	0.10
7.0			8.38	6.17	3.73	2.50	1.79	1.05			20.2	9.65	2.90	1.11	0.50	0.14
8.0			9.58	7.05	4.27	2.86	2.05	1.20			25.7	12.3	3.69	1.41	0.63	0.17
9.0			10.8	7.93	4.80	3.22	2.30	1.35			31.8	15.2	4.56	1.74	0.78	0.22
10.0				8.81	5.34	3.57	2.56	1.49			18.4	5.51	2.11	0.95	0.26	
11.0				9.69	5.87	3.93	2.82	1.64			21.8	6.54	2.50	1.12	0.31	
12.0				10.6	6.40	4.29	3.07	1.79			25.5	7.65	2.92	1.31	0.36	
13.0					6.94	4.65	3.33	1.94				8.84	3.38	1.52	0.42	
14.0					7.47	5.00	3.59	2.09				10.1	3.86	1.73	0.48	
15.0					8.00	5.36	3.84	2.24				11.4	4.37	1.96	0.54	
16.0					8.54	5.72	4.10	2.39				12.9	4.91	2.21	0.61	
17.0					9.07	6.08	4.35	2.54				14.3	5.48	2.46	0.68	
18.0					9.60	6.43	4.61	2.69				15.9	6.07	2.73	0.75	
19.0					10.1	6.79	4.87	2.84				17.5	6.70	3.01	0.83	
20.0					10.7	7.15	5.12	2.99				19.2	7.35	3.30	0.91	
25.0						8.94	6.40	3.74					11.0	4.93	1.35	
30.0						10.7	7.68	4.48					15.3	6.85	1.88	
35.0							8.96	5.23						9.06	2.48	
40.0							10.2	5.98						11.5	3.16	
45.0								6.73							3.91	
50.0								7.47							4.73	
55.0								8.22							5.62	
60.0								8.97							6.58	
65.0								9.72							7.61	
70.0								10.5							8.70	
75.0								11.2							9.86	

Flow Velocity above 8 feet per second may be considered excessive and may result in excessive pressure loss.

Shown is pressure loss in units of psi per 100 feet of pipe.

Example: for 200 lineal feet of pipe, double the value listed in this table.

Table 4.12: RAUPEX Pipe With 50% Water / 50% Propylene Glycol (continued)

Flow Rate GPM	pressure loss in psi per 100 ft of RAUPEX pipe															
	140°F (60°C) 50% Glycol								180°F (82°C) 50% Glycol							
	3/8"	1/2"	5/8"	3/4"	1"	1 1/4"	1 1/2"	2"	3/8"	1/2"	5/8"	3/4"	1"	1 1/4"	1 1/2"	2"
0.2	0.32	0.08	0.03	0.02	<.01	<.01	<.01	<.01	0.31	0.07	0.03	0.01	<.01	<.01	<.01	<.01
0.3	0.66	0.16	0.07	0.03	<.01	<.01	<.01	<.01	0.63	0.15	0.06	0.03	<.01	<.01	<.01	<.01
0.4	1.11	0.27	0.11	0.05	0.02	<.01	<.01	<.01	1.06	0.25	0.10	0.05	0.02	<.01	<.01	<.01
0.5	1.66	0.40	0.16	0.08	0.02	<.01	<.01	<.01	1.58	0.38	0.16	0.07	0.02	<.01	<.01	<.01
0.6	2.30	0.55	0.23	0.11	0.03	0.01	<.01	<.01	2.19	0.52	0.22	0.10	0.03	0.01	<.01	<.01
0.7	3.03	0.73	0.30	0.14	0.04	0.02	<.01	<.01	2.88	0.69	0.28	0.14	0.04	0.02	<.01	<.01
0.8	3.84	0.92	0.38	0.18	0.05	0.02	<.01	<.01	3.66	0.88	0.36	0.17	0.05	0.02	<.01	<.01
0.9	4.75	1.14	0.47	0.22	0.07	0.03	0.01	<.01	4.52	1.08	0.44	0.21	0.06	0.02	0.01	<.01
1.0	5.73	1.37	0.56	0.27	0.08	0.03	0.01	<.01	5.46	1.31	0.54	0.26	0.08	0.03	0.01	<.01
1.1	6.80	1.63	0.67	0.32	0.10	0.04	0.02	<.01	6.48	1.55	0.64	0.31	0.09	0.04	0.02	<.01
1.2	7.95	1.91	0.78	0.37	0.11	0.04	0.02	<.01	7.58	1.81	0.74	0.36	0.11	0.04	0.02	<.01
1.3	9.18	2.20	0.90	0.43	0.13	0.05	0.02	<.01	8.75	2.09	0.86	0.41	0.12	0.05	0.02	<.01
1.4	10.5	2.51	1.03	0.49	0.15	0.06	0.03	<.01	9.99	2.39	0.98	0.47	0.14	0.05	0.02	<.01
1.5	11.9	2.84	1.17	0.56	0.17	0.06	0.03	<.01	11.3	2.71	1.11	0.53	0.16	0.06	0.03	<.01
1.6	13.3	3.19	1.31	0.63	0.19	0.07	0.03	<.01	12.7	3.04	1.25	0.60	0.18	0.07	0.03	<.01
1.7	14.9	3.56	1.46	0.70	0.21	0.08	0.04	<.01	14.2	3.39	1.39	0.67	0.20	0.08	0.03	<.01
1.8	16.5	3.94	1.62	0.77	0.23	0.09	0.04	0.01	15.7	3.76	1.54	0.74	0.22	0.09	0.04	0.01
1.9	18.2	4.35	1.78	0.85	0.26	0.10	0.04	0.01	17.3	4.14	1.70	0.81	0.24	0.09	0.04	0.01
2.0	19.9	4.77	1.96	0.94	0.28	0.11	0.05	0.01	19.0	4.54	1.86	0.89	0.27	0.10	0.05	0.01
2.5	29.7	7.12	2.92	1.40	0.42	0.16	0.07	0.02	28.4	6.78	2.78	1.33	0.40	0.15	0.07	0.02
3.0	41.3	9.88	4.05	1.94	0.58	0.22	0.10	0.03	39.4	9.42	3.86	1.85	0.55	0.21	0.10	0.03
4.0		16.6	6.80	3.25	0.98	0.37	0.17	0.05		15.8	6.48	3.10	0.93	0.36	0.16	0.04
5.0		24.8	10.2	4.86	1.46	0.56	0.25	0.07		23.6	9.69	4.63	1.39	0.53	0.24	0.07
6.0		34.4	14.1	6.75	2.02	0.77	0.35	0.10		32.8	13.5	6.43	1.93	0.74	0.33	0.09
7.0			18.6	8.91	2.67	1.02	0.46	0.13			17.8	8.49	2.55	0.97	0.44	0.12
8.0			23.7	11.3	3.40	1.30	0.58	0.16			22.6	10.8	3.24	1.24	0.56	0.15
9.0			29.3	14.0	4.20	1.61	0.72	0.20			28.0	13.4	4.01	1.53	0.69	0.19
10.0				16.9	5.08	1.94	0.87	0.24				16.2	4.85	1.85	0.83	0.23
11.0				20.1	6.04	2.31	1.04	0.28				19.2	5.76	2.20	0.99	0.27
12.0				23.6	7.06	2.70	1.21	0.33				22.5	6.74	2.57	1.16	0.32
13.0					8.16	3.12	1.40	0.38					7.79	2.97	1.33	0.37
14.0					9.33	3.56	1.60	0.44					8.90	3.40	1.53	0.42
15.0					10.6	4.04	1.81	0.50					10.09	3.85	1.73	0.47
16.0					11.9	4.54	2.04	0.56					11.3	4.33	1.94	0.53
17.0					13.3	5.06	2.27	0.62					12.6	4.83	2.17	0.59
18.0					14.7	5.61	2.52	0.69					14.0	5.35	2.40	0.66
19.0					16.2	6.19	2.78	0.76					15.5	5.90	2.65	0.73
20.0					17.8	6.79	3.04	0.84					17.0	6.48	2.91	0.80
25.0						10.2	4.56	1.25						9.70	4.35	1.19
30.0						14.1	6.34	1.74						13.5	6.05	1.66
35.0							8.38	2.30							8.00	2.19
40.0							10.7	2.92							10.2	2.79
45.0								3.62								3.46
50.0								4.38								4.18
55.0								5.21								4.97
60.0								6.09								5.82
65.0								7.05								6.73
70.0								8.06								7.70
75.0								9.14								8.73

To express pressure loss in terms of feet of head, multiply the value listed by 2.307.

Example: 1 psi = 2.307 feet of head

4.2 Fittings - EVERLOC

The REHAU EVERLOC fitting system employs the memory inherent in RAUPEX pipe to form a secure joint. The RAUPEX pipe is expanded to allow the fitting to be inserted. Because of its crosslinked structure, the pipe tries to return to its original shape, placing significant force on the fitting and forming a tight joint.

A properly installed EVERLOC fitting can be placed in areas that will become inaccessible after installation, such as behind sheetrock walls or under a floor or slab. Always check with local codes to verify which types of joints, if any, may be used in inaccessible locations.

Note: EVERLOC fittings are designed for use exclusively with RAUPEX pipe and must be assembled only with REHAU EVERLOC fitting tools. REHAU does not monitor the compatibility of EVERLOC fittings with other brands of PEX pipe. The designer must verify all combinations other than EVERLOC and RAUPEX.

All EVERLOC fittings are produced for RAUPEX pipe manufactured to ASTM F2080. The EVERLOC fitting system offers a variety of configurations to meet different radiant piping system applications. Threaded EVERLOC adapter fittings have tapered threads and are National Pipe Thread. EVERLOC offers the following adapter connections: female NPT, male NPT and sweat and street solder connections.

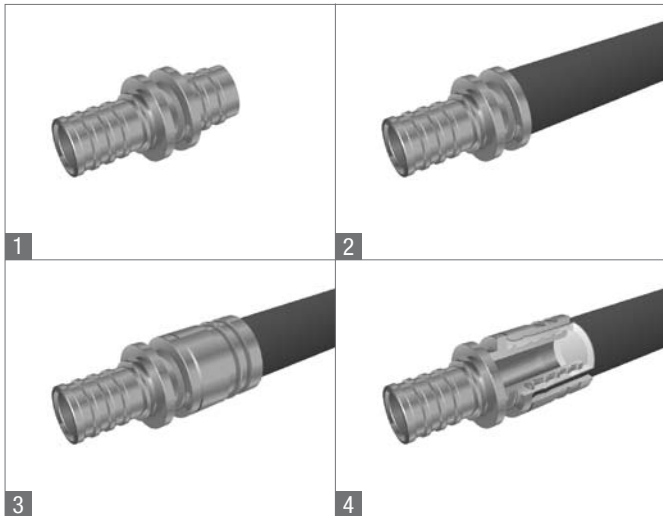

Fig. 4.4: (1) EVERLOC fitting, (2) fitting inserted in expanded pipe, (3) REHAU EVERLOC joint, (4) cutaway

4.2.1 Fitting Material

EVERLOC fittings are manufactured from UNS C36000 or C37700 brass, or equivalent European standard.

4.2.2 Fitting Performance Characteristics

Stress Crack Resistance

Brass fittings and components can be susceptible to stress corrosion cracking. Radiant systems subject fittings to stresses from thermal cycling, mechanical loading (e.g., caused by over tightening of a threaded fitting) and the presence of chemicals in the interior water or exterior air.

NOTICE: Brass fittings and components should not be exposed to harmful chemicals or aggressive water conditions. Failure to follow this instruction may damage the parts resulting in leaks and operational failures.

Friction Loss

The pressure loss due to friction through an EVERLOC fitting may be determined using a two-step calculation. First, using Table 4.13, the pressure loss through the fitting is represented by the equivalent length of RAUPEX pipe. Second, from Tables 4.8 to 4.12, the equivalent pipe length is used to calculate the pressure loss of the fitting.

Table 4.13: Fitting Pressure Loss Expressed as Equivalent Length of Pipe

Fitting Size	Equivalent Length of RAUPEX Pipe in ft (m)				RAUPEX 90° Pipe Bend
	Tee Run	Tee Branch	90° Elbow	Coupling	
3/4 in	1.0 (0.3)	6.4 (2.0)	6.2 (1.9)	0.8 (0.2)	0.6 (0.2)
1 in	1.4 (0.4)	8.2 (2.5)	8.3 (2.5)	1.1 (0.3)	0.6 (0.2)
1 1/4 in	1.0 (0.3)	12.0 (3.7)	12.0 (3.7)	1.0 (0.3)	1.0 (0.3)
1 1/2 in	1.0 (0.3)	13.0 (4.0)	13.0 (4.0)	1.0 (0.3)	1.0 (0.3)
2 in	1.0 (0.3)	15.0 (4.6)	15.0 (4.6)	1.0 (0.3)	1.0 (0.3)

4.2.3 Protecting Buried EVERLOC Fittings

EVERLOC brass is designed for rugged conditions and long life. However some materials, such as Portland cement, may corrode brass. All buried EVERLOC fittings must be covered with tightly wrapped, waterproof, silicone tape or heat shrink sleeving to prevent contact with corrosive chemicals.

Note: EVERLOC fittings may be buried in concrete when properly protected. Check the local codes to determine if this is an acceptable practice.

4.2.4 Installing EVERLOC Fittings

Installing EVERLOC fittings requires special REHAU tooling. Refer to the REHAU *Radiant Heating Installation Guide* for the tools required depending on the fitting and pipe sizes.

The basic process of completing an EVERLOC joint is to:

- Install sleeve over end of pipe
- Expand the RAUPEX pipe
- Insert fitting into end of pipe
- Compress the sleeve over the pipe and fitting

4.3 Fittings - Compression Nut

The REHAU compression nut fitting is used where pipe remains accessible after installation. It allows easy disassembly of the pipe from the connected device such as a manifold, another fitting or a piece of equipment. The fitting can be assembled with a pipe wrench and does not require special REHAU tooling. REHAU compression nut fittings meet the requirements of ASTM F877 and CSA B137.5.

The basic process of completing a compression nut joint is to:

- Install compression union nut, then split clamping ring over end of pipe
- Insert fitting into end of pipe
- Tighten nut onto fitting

R20 Fittings are removable, threaded connections that transition the RAUPEX heating circuit pipe into the PRO-BALANCE or HLV manifold.

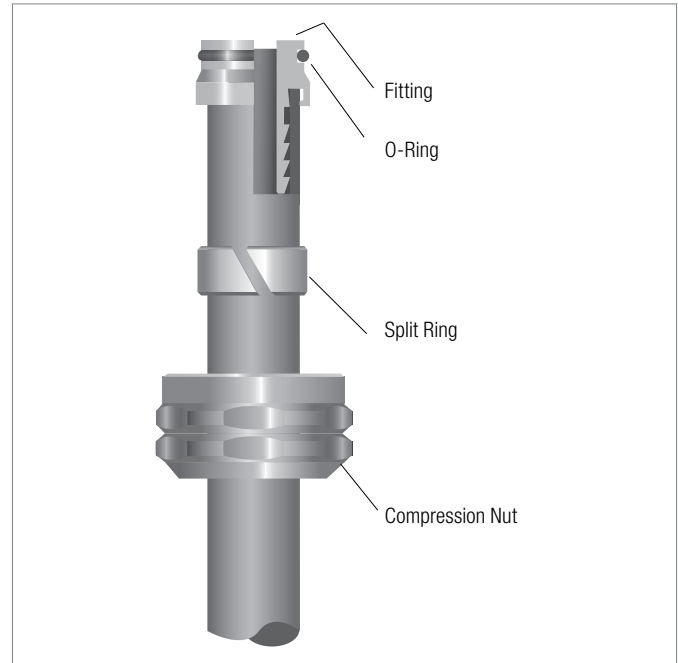

Fig. 4.5: R20 connection to manifold

Copper Adapters Fittings transition the RAUPEX distribution pipe to copper pipe.

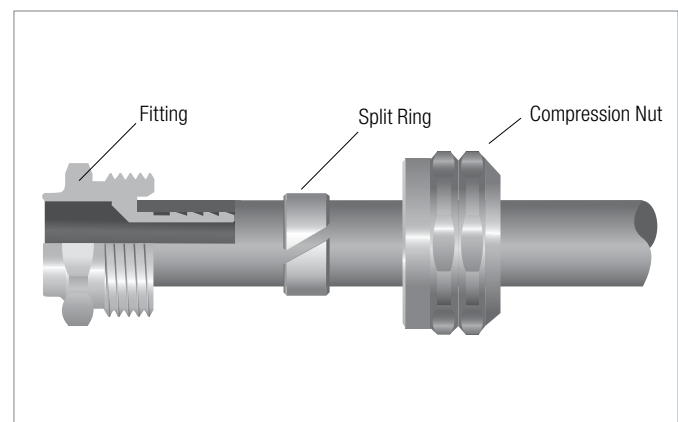

Fig. 4.6: Adapter connection to copper pipe

NOTICE: Adapter fittings may leak if not properly maintained. Periodically check and retighten adapter fittings to reduce risk of leaks.

4.4 Manifolds

Manifolds distribute and control the heating water to the different circuits in a radiant heating system. Manifolds may be mounted in any orientation (e.g., inverted, horizontal or sideways).

PRO-BALANCE and **PRO-BALANCE XL Manifolds** have separate supply and return headers. Circuit connections branch off from the headers and balancing valves control the flow rate to each circuit connection. A valve actuator may be installed to the header balancing valve to open and close the circuit.

HLV Manifolds have separate supply and return headers. These "valve-less" manifolds have circuit connections that connect directly to the pipe. Manifolds may be used when circuit lengths are within 10% and flow rate requirements are the same for all circuits.

Ball Valve and **Cut-to-Length Manifolds** have a single header and the pipe circuit connections are accomplished with the permanent EVERLOC fitting.

Pre-cut and **Header Stock Manifolds** have a single header and smaller copper tube outlet tees for connecting to the radiant heating circuit.

Manifold Cabinets are used with the PRO-BALANCE and HLX manifolds in commercial, industrial and institutional applications.

4.5 Heat Transfer Panels

Heat transfer panels overlay the subfloor and contain channels which accept the RAUPEX pipe. REHAU's patented RAUPANEL Radiant Heating System consists of RAUPEX pipes, aluminum panels, plywood return bends and plywood furring strips. These components are designed for ease of installation as well as excellent thermal performance. The system allows for either 6 or 8 in (15 or 20 cm) on-center pipe

spacing, as required to meet radiant panel performance requirements.

RAUPANEL is an extruded aluminum panel which has a custom Omega-shaped groove that allows pipe to be tightly snapped into place, maintaining excellent thermal contact between the pipe and panel. The pipe installation does not require silicone or other filler materials. The unique profile of the highly-conductive aluminum panel makes it responsive, strong and lightweight. Five integral legs on the bottom support the panels, the weight of the flooring and the loads above, while reducing the thermal contact with the subfloor below. This reduced contact increases the directional efficiency of the panels, since the majority of the heat drawn from the RAUPEX pipe is conducted across the top surface of the panel and to the floor, wall or ceiling panel. This often means that no insulation is required in a joist cavity below the panel system, saving installation time and material costs.

Plywood Return Bends are configured to maintain the pipe spacing during installation. The 6 in (15 cm) on-center return bends allow for aluminum panels to be installed side-by-side, providing maximum aluminum coverage in areas where even more heat delivery is required. The 8 in (20 cm) on-center return bends are specially notched to align the aluminum panels and the pipe groove, simplifying system installation. Return bends are machined from construction-grade plywood to match the height of the aluminum panels, and are pre-grooved for easy pipe installation.

Plywood Furring Strips provide nailing surfaces for certain types of flooring. These precision-cut furring strips are used primarily with 8 in (15 cm) return bends to fill the gaps between the aluminum panels. They are also used at the edges of panel layouts to provide nailing surfaces and to keep a space between the aluminum panels and outside wall plates and studs, reducing heat loss through exterior walls. Furring strips are machined from construction-grade plywood to match the height of the aluminum panels.

Table 4.14: Manifold Comparison

	Distribution Supply and Return Sizes	Number of Circuits	Maximum Flow (GPM)	Circuit Isolation	Flow Gauges with Manual Balancing Adjustment	Automatic Control Valves	Circuit Connections
PRO-BALANCE	1 in NPT	2 to 12	20	√	√	√*	R20
PRO-BALANCE XL	1 1/4 in NPT	2 to 10	40	√	√	√*	R20
HLV	1 in NPT	2 to 5	20	√			R20
Ball Valve	1 in Cu pipe	12	20	√			EVERLOC
	1 1/4 in Cu pipe	12	32	√			EVERLOC
Cut-to-Length	1 in Cu pipe	12 or 24	20				EVERLOC
	1 1/4 in Cu pipe	12 or 24	32				EVERLOC
Pre-cut	1 in Cu pipe	2 to 4	20				Cu pipe
Header Stock	1 in Cu pipe	24	20				Cu pipe
	1 1/4 in Cu pipe	24	32				Cu pipe
	1 1/2 in Cu pipe	24	44				Cu pipe
	2 in Cu pipe	18 or 24	75				Cu pipe

4.6 Heat Transfer Plates

Heat transfer plates are installed below the subfloor in the joist cavity and contain channels which accept the RAUPEX pipe. Installations are typically 8 in (20 cm) on-center with two pipes running the length of each joist cavity.

RAUPLATE™ Heat Transfer Plates are fixed to the underside of a suspended joist space floor. Each plate has two channels spaced 8 in (20 cm) on-center. The RAUPEX pipes clip quickly and firmly into the channels. RAUPLATE typically offers faster and easier installation than other heat transfer plates.

Heavy Gauge Heat Transfer Plates are fixed to the underside of a suspended joist space floor. The single-channel plates are used when there is only one run of pipe in the joist cavity or to position the pipe around obstructions where the two-channel plates do not fit. The RAUPEX pipes clip firmly into the channel.

4.7 Installation Accessories

Accessories are used in a variety of radiant heating construction methods.

4.7.1 Pipe Assembly Guides

Steel and Polymer Support Bends assists the installer in creating 90° bends of the distribution piping and circuit tails without kinking the pipe. The support bends snap over the pipe.

4.7.2 Pipe and Fitting Protection

PVC Bend Guides provide protection at slab penetrations and create a professional appearance. Pipe is inserted into the 90° rigid PVC guides, then half of each guide is embedded in the slab.

PE Protection Sleeves protect the pipe at slab, wall and joist penetrations, expansion and construction joints, and abrasive surfaces. The protection sleeves reduce abrasion and minimize noise caused by the expansion and contraction of the pipe.

RAUCROSS™ Sleeving is ideal for sealing around EVERLOC brass fittings installed in corrosive environments or buried in a slab. The heat shrink sleeving tightly seals around the fitting with heat from a hot air gun.

4.7.3 Pipe Hangers

Locking Clips allow for rapid installation of pipe. The pipe snaps into the clips and can be removed without damaging the clips. The polymer clips attach to the surface with a screw or nail (not included).

Pipe Talons clip onto the pipe. **Single Nail Clamps** completely encircle the pipe. Both the polymer talon and polymer clamp secure the pipe to the wood framework with a pre-installed barbed nail.

Isolating Suspension Clamps secure suspended pipe to both wood and metal framework.

Plastic Pipe Clamps secure pipe to both wood and metal framework.

Nylon Pipe Ties safely secure pipe directly to slab reinforcing bars or wire mesh. This installation method is most common in commercial applications.

Insulation Screw Clips secure the pipe directly to rigid board insulation which is an aid when laying pipe, and prevents the pipe from floating up to the surface with wet construction methods. The polymer screw clips insert easily into the insulation with the aid of the screw clip tool provided separately.

Plastic Holding Pins secure the pipe directly to rigid insulation which is an aid when laying pipe, and prevents the pipe from floating up to the surface with wet construction methods.

Soil Hooks anchor pipe in compacted soil.

4.7.4 Pipe Rails

RAILFIX™ Rails allow for rapid installation by securing the pipe prior to pouring the slab or overpour in a wet construction method. The rigid polymer channel has fixed pipe slots spaced every 2 in (5 cm).

Universal Fixing Rails allow for the same rapid installation as the RAILFIX with the added benefit that four different pipe sizes, ranging from 3/8 to 3/4 in., may be secured. The rigid polymer molding has alternating small and large pipe tabs spaced every 4 in (10 cm).

Fixing rails may be mounted onto insulation with Plastic Holding Pins or onto concrete and wood floors with screws.

Table 4.15: Accessory Comparison

	Construction Methods		Distribution Piping and Circuit Tails
	Wet	Dry	
Support Bends			√
Bend Guides	√		
Protection Sleeves	√	√	
RAUCROSS Sleeving	√		
Locking Clips			√
Pipe Talons		√	√
Single Nail Clamps			√
Plastic Pipe Clamps			√
Isolating Suspension Clamps			√
Nylon Pipe Ties	√		
Insulation Screw Clips	√		
Plastic Holding Pin	√		
Soil Hooks	√		√
RAILFIX Rails	√	√	√
Universal Fixing Rails	√	√	√

5. SYSTEM PLANNING

Planning and designing a radiant heating system involves many objectives: economy, comfort, zoning and use of space. This chapter identifies the information the designer needs to gather and understand before beginning the system design of a specific installation.

REHAU provides a general construction specification that can be included in the project's master plan. The specification is intended to be edited by the designer to meet the needs of the project. The REHAU *Radiant Heating Specification* may be obtained from the REHAU Resource Center.

5.1 Building Layout

To do an accurate and complete job, the radiant designer needs a current set of drawings and specifications for the building. The designer also needs a clear understanding of any additional heating and ventilation systems to be used, and the ability to discuss certain design issues with the owner and/or the owner's agent.

The building's structure and the floor finish installation influences the decision regarding the best radiant heating construction method. Floor construction methods play an important role in the performance of the radiant heating system. The floor should allow for the heat from the pipes to dissipate readily and evenly to the heated space. Downward heat flow should be minimized by employing adequate insulation. Certain radiant construction methods involve penetrations through floor joists or other details which may be governed by local codes. Check with applicable code authorities to determine specific requirements.

Walls and ceilings may be used in retrofit projects to increase the radiant heat output of rooms with floor areas too small to provide sufficient heat.

5.2 Building Heat Loss

The designer needs to calculate the building heat loss before designing a radiant heating system. A heat loss calculation is performed, based on the outdoor design temperatures, and taking into account conductive heat loss through all exterior building panels (e.g., walls, ceilings, floors, windows and doors) and air changes related to air infiltration and mechanical ventilation. In some cases, heat loss through interior building panels is also calculated, such as where temperature differences exist between adjacent rooms. When designing a building with radiant heating, special attention must be paid to the radiant

panels themselves, as the heat lost through a heated floor may be higher than the heat lost through an unheated floor.

Calculations for heat loads are typically based on outside design temperatures for the project location, and do not assume other sources of heat gain, such as solar gain, heat from occupants, machinery, computers or lights. This results in a heating system that is sized correctly for worst-case conditions with no artificial sources of heat gain.

Several heat loss calculation methods are used throughout North America. Different heat load calculation techniques apply to residential, commercial, industrial and institutional facilities. Certain building codes require the use of specific heat loss programs. Determine the applicable laws by checking with the local municipality and/or building inspection department. To design a radiant heating system, the heat loss calculations should be performed according to one of the following standards or equivalent:

- ASHRAE
- ACCA - Manual J (residential)
- ACCA - Manual N (commercial)

Detailed heat loss calculations must be done as accurately as possible to accurately size all system components—the heat source, distribution pipes, manifolds, valves, circulator pumps, expansion tanks and other hydronic components. Under sizing components can result in a heating system that does not meet the demand at peak load. Over sizing components can result in short-cycling of boilers or circulator pumps, noise and vibration, poor control over heating water or room temperatures, inadequate comfort and loss of efficiency. In some cases, components can fail if not sized correctly.

5.3 Room and Building Temperatures

In the planning stage, the designer should consider the thermal comfort of the occupants. Be sure to consult with the building owner regarding the desired target temperature setpoint. The thermal comfort for a person in a room is determined by the activity of the person, clothing worn by the person, ambient room temperature, air speed, humidity and surface temperatures in the room (e.g., walls, floors, ceilings and furniture). Radiant heating systems warm surfaces, objects and air in the lower portions of the space, allowing thermostats to be lowered 2 to 4°F (1 to 2°C) compared to conventional forced-air heating systems without sacrificing the occupants thermal comfort level.

Typical Room Ambient Air Temperatures

Typical target ambient room temperatures used for a radiant heating design are:

- 60-65°F (16-18°C) for most warehouses
- 65-68°F (18-20°C) for most occupied spaces
- 70-74°F (21-23°C) for most bathrooms

Maximum Radiant Panel Surface Temperatures

Radiant floors are an excellent heating source.

Floor temperature limitations exist to ensure occupants feet are not overheated, while still providing enough heat to meet the room requirement.

Table 5.1: Typical Maximum Floor Surface Temperatures

Human Comfort Exposure Limits	Temperature °F (°C)
Floors in occupied areas	85 (29)
Floors in perimeter areas	95 (35)
Floors in bathrooms	91 (33)
Floors in distribution areas such as hallways and secondary rooms	95 (35)

Walls and ceilings are allowed to have higher temperatures because of their limited contact with occupants. Wall temperatures may be as high as 95°F (35°C). Ceiling temperatures may be even higher, depending on the ceiling height.

NOTICE: Excessive temperatures can overheat and damage floor, wall and ceiling structures or coverings causing discoloration, warping or cracking. Ensure that your radiant designs conform to the maximum allowable temperature defined by the manufacturer of these materials.

5.4 Building Zoning

With radiant heating, thermal zoning is accomplished by controlling the flow of water through individual pipe circuits or manifolds. Zones can be as small as a bathroom or bedroom, or as large as an entire building. Zoning is accomplished by controlling the flow of water through individual pipe circuits or manifolds. A zone may have just one circuit of radiant heat or may have many circuits that operate together. A zone may have just one circuit of radiant heat or may have many circuits that operate together.

Building Use

Zoning the radiant heating system considers the use of the building in addition to the target ambient temperature requirements of the occupants.

Residential: Residents will typically use different rooms, such as bedrooms versus kitchens, at different times of the day. Rooms that are used together should be zoned together. Rooms that are not used for substantial periods of time, such as formal dining areas, should be zoned separately, so that thermostats can be set back to conserve energy and reduce operating costs.

Commercial: Commercial buildings usually include one or two types of activities, such as eating or shopping, and may change over the life of the building. Zoning should be versatile enough to accommodate changes in use patterns.

Industrial: The industrial process usually determines the zoning, and may also involve large pieces of machinery which may add to the heat in the room.

5.5 Insulation

Insulation systems are very important for achieving the designed radiant heating panel performance. Downward and edge heat losses from radiant panels may be significant, up to 50%, if the proper insulation methods are not installed. With recommended insulation levels, the downward heat loss can be as low as 10% of the total heat load. Insulation behind radiant panels is critically important to direct the flow of heat correctly, to improve response time and to maximize energy efficiency. In between floors, insulation helps to improve the system performance and room temperature control. Many types of insulation may be used, depending on the application and local codes.

Note: Check your state, provincial or local codes to ensure your design complies with minimum insulation requirements, if they exist.







5.6 Floor Coverings

Floor products used with radiant heating systems should have high heat transmission values (low R-values) to achieve the best possible heat transfer from the pipes to the room. Floor coverings should also be as thin and dense as possible and be able to withstand the heat output of the radiant panel. Every floor covering has a specific temperature limit. Some typical examples of flooring R-values and suggested maximum allowable temperatures are shown in Table 5.2. Wood floors are the most sensitive to heat output from radiant panels.

NOTICE: Flooring products can be damaged by improperly designed radiant systems leading to discoloration, noise, delamination, warping, cracking and deterioration of the flooring products.

- Verify floor products are approved for use with radiant heating systems
- Check floor temperatures are within the limitations set by the manufacturer of the floor coverings, underlayments, adhesives and grouts

Table 5.2: Maximum Temperatures and R-values for Typical Floor Coverings

Finished Floor Surface		Maximum Subfloor Surface Temp* °F (°C)	Thickness in (mm)	Resistance R-value h•ft ² •°F/BTU (m ² •K/W)
Bare floor		N/A	N/A	0
Solid hardwood		85° (27°)	3/4 in (19 mm)	0.68 (.12)
Laminated hardwood with adhesive		90° (32°)	11/16 in (17 mm)	0.87 (.15)
PVC/linoleum with adhesive		100° (38°)	3/16 in (4 mm)	0.26 (.05)
Ceramic tile floor with mortar bed (elastometric bonding agent)		100° (38°)	1/4 in (6 mm)	0.23 (.04)
Natural stone with mortar bed		100° (38°)	1 1/2 in (38 mm)	0.21 (.03)
Carpet (polyester) with rubber pad		88° (31°)	3/8 in (9 mm)	1.17 (.21)

*Note: Typical values presented; the designer must verify actual limits of the selected finish flooring materials with the manufacturer

Solid Hardwood

Radiant heating can be installed with solid hardwood flooring with very good results as long as the radiant panel design adheres to moisture limits, floor temperature limits and installation considerations. Many species of solid hardwood flooring can withstand the radiant panel surface temperatures. Information on a specific species of hardwood may be obtained from the manufacturer as well as from the Radiant Panel Association (www.radiantpanelassociation.org), the National Wood Flooring Association (<http://www.nwfa.org>) and The Hardwood Council (www.hardwoodcouncil.com).

Engineered Hardwood or Laminate Hardwood

Engineered hardwood and laminate hardwood floors are an excellent choice for use with radiant heated floors. With higher density and lower thickness, these flooring solutions are often more conductive (lower R-value) than solid hardwood flooring. This flooring is usually compatible with radiant panel surface temperatures, and because it absorbs less moisture than solid hardwoods, it is more suitable for wet construction methods.

Engineered hardwood flooring has a thin top layer of solid hardwood, typically 1/16 to 1/8 in (2 to 3 mm) thick, bonded to plywood underneath. With a solid hardwood surface, engineered hardwood floors are available in many species and colors yet offer the structural stability of plywood.

Laminate flooring is usually melamine-infused paper bonded to a fiberboard core. Laminate floors are available in patterns and colors,

and offer the structural stability of the fiberboard material. Additional information may be obtained from the Laminate Flooring Site (www.thelaminateliftingsite.com) or Laminate Floorings (www.Laminate-Floorings.net).

Vinyl and Linoleum

Vinyl tiles are highly affected by floor temperatures. Consult with the manufacturer to determine the maximum radiant panel surface temperature allowable for the adhesive and the covering.

Ceramic Tile, Natural Stone or Bare Concrete

Ceramic tile, pavers, marble, stamped or stained bare concrete, and other stone finishes are ideal for radiant surfaces. An underlayment (e.g., backerboard or isolation membrane) is installed between the radiant panel and the tile/stone to reduce movement and isolate cracks. Tile cement with high heat capability should be used.

Carpeting and Padding

Carpeting and padding may be used over a radiant heated floor if properly selected. Carpet and carpet pads with relatively high R-values, such as urethane carpet and pads, will significantly reduce the radiant heating performance, and are not recommended. Typical carpet pads suitable for radiant floors are made from thin slab rubber, synthetic fiber, or styrene butadiene rubber (SBR). Consult with the manufacturer to determine the maximum radiant panel surface temperature allowable for the carpet, pad and adhesives, if used. Additional information may be obtained from the Carpet and Rug Institute (www.carpet-rug.org).

5.7 Wet Construction Joints

A heated slab, which is one type of thermal mass, is subject to movement. This can be caused by shrinkage, which occurs only once when the thermal mass dries, or as a result of expansion and contraction from heating the thermal mass. Typically, these movements occur in the width and length of the flooring surface. However, vertical movements (bowing) may also be caused by differences in expansion at the surface and base of the thermal mass.

Movement resulting from the temperature difference due to heating can be estimated using the linear expansion formula in Section 4.1.4:

Example, given:

$$L = 25 \text{ ft}, \Delta T = 55^\circ\text{F}, \alpha = 6.1 \times 10^{-6}/^\circ\text{F}$$

(α value changes with thermal mass type)

Longitudinal expansion of the thermal mass layer
 $\Delta L = .0084 \text{ ft}$ or $.10 \text{ in}$ (3 mm)

The design must allow for absorption of the movement of the thermal mass. To prevent uncontrolled cracking, the architect may segment the thermal mass into smaller sections called thermal bays by employing an appropriate arrangement of movement joints.

5.7.1 Joint Types

Edge Joints

Edge joints surround the thermal mass and are formed by the installation of an edge insulating strip. It is important that edge insulating strips are rigid enough to withstand compression from the wet thermal mass and soft enough to absorb movements.

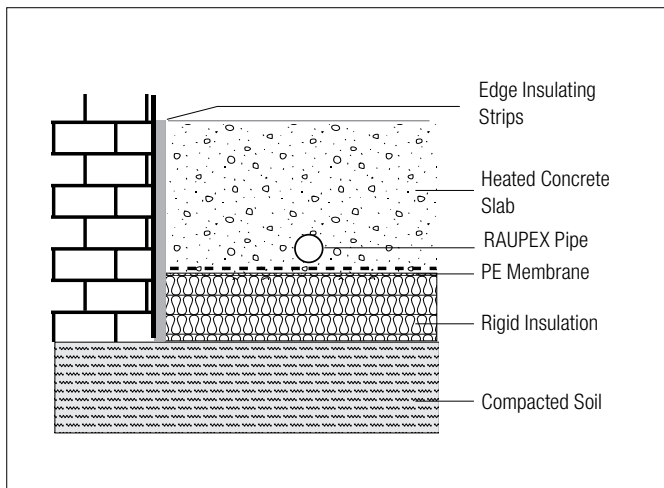

Fig.5.1: Edge joint

Movement Joints

As a result of their construction, movement joints are capable of absorbing major horizontal and vertical (structural) movement. Movement joints are used to separate thermal mass bays and must always be incorporated above structural expansion joints in the building structure. Movement joints should have a width of at least 3/8 in (8 mm).

NOTICE: Whenever heating pipes cross movement joints, a protective sleeve must encase the pipe. Failure to encase the pipe may damage the pipe resulting in leaks and operational failures.

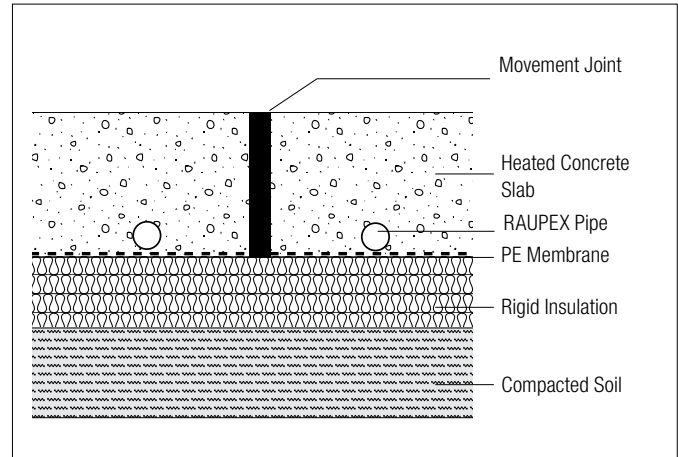

Fig. 5.2: Movement joint

Contraction Joints

Contraction joints are cut into the wet thermal mass down about one-third to one-half of the thermal mass depth. Their purpose is to prevent uncontrolled cracking. Contraction joints generally have a temporary function. They are only capable of absorbing movements resulting from thermal mass shrinkage and are filled with synthetic resin mortar or similar material after contraction has taken place. They are used to further divide areas already separated by movement joints. Contraction joints should not be used in doorways. Their use should be limited to bay sizes up to $16 \times 16 \text{ ft} = 256 \text{ ft}^2$ (25 m^2), and cases where soft floor finishes are used.

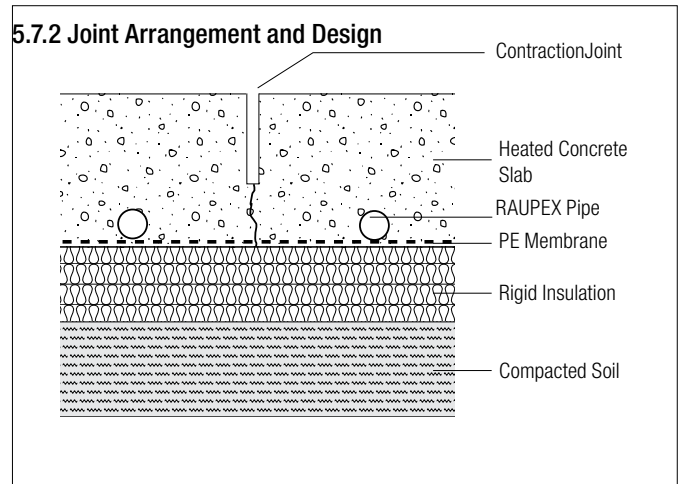

Fig. 5.3: Contraction joint

5.7.2 Joint Arrangement and Design

The structural engineer or designer specifies the location of joints in the joint plan. Joints are needed:

- At the edge of the thermal mass to allow for thermal mass movement
- Along structural expansion joints in the building
- In doorways
- With L-shaped thermal mass bays
- With thermal mass surfaces greater than 430 ft² (40 m²)
- With side lengths greater than 26 ft (8 m)
- With side ratios L/W greater than 2:1

Note: Incorrect arrangement and design of joints are the most common causes of damage to thermal mass floors.

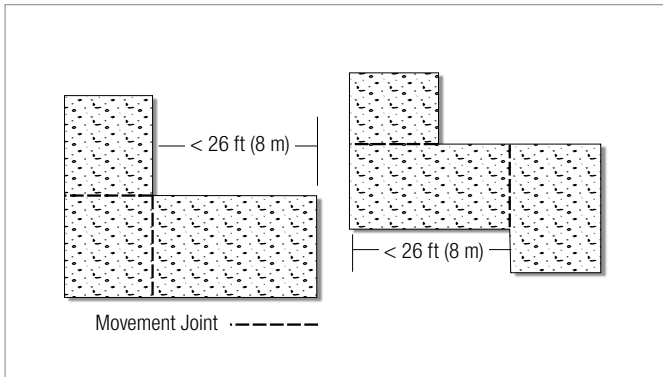

Fig. 5.4: Location of thermal mass joints

The layout of the heating pipe and the thermal mass joints must be coordinated by the designer and the architect. Pipe circuits are to be planned and installed such that they do not cross movement joints as shown in Fig. 5.5. Movement joints should only be crossed by the connection piping (circuit supply and return tails).

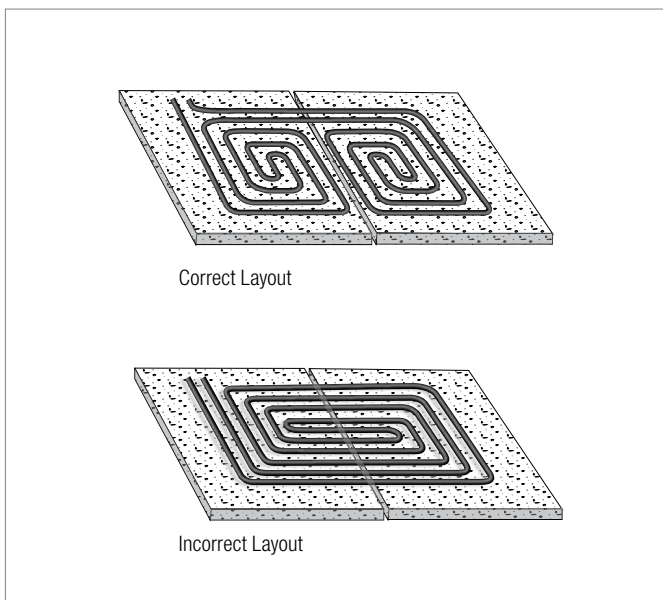

Fig. 5.5: Layout of radiant heating pipe with a thermal mass joint

When the pipe crosses a thermal mass joint, it must be protected from shearing forces with a protective sleeve as shown in Fig. 5.6. Pipe protection should extend at least 15 in (38 cm) on either side of the joint.

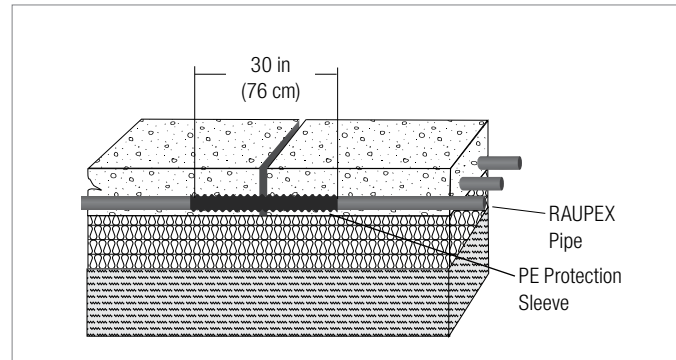

Fig. 5.6: Protective sleeving through movement joint

5.7.3 Influence of Thermal Mass Joints on Floor Finishes

To avoid cracking, each type of floor finish has different joint requirements. For hard coverings (e.g., ceramic tiles), the joints must continue as far as the upper surface of the floor finish. This measure is also recommended for soft floor coverings (e.g., carpet and vinyl tile) to prevent bowing or channeling.

5.8 Heat Source

Radiant heating systems allow the designer considerable freedom when specifying the heat source which supplies the heating water. A properly-designed radiant system will use a much lower water temperature than other hydronic heat emitters. In this regard, radiant heating could be considered a "warm-water" heating system rather than a "hot-water" heating system.

The heat source is designed to match the heat loss of the building, or heated area, plus other heat loads, such as losses to the ground and the requirements of domestic hot water, swimming pools, snow and ice melting or other heat emitters. The heat source must be sufficient to supply the total heat required by all loads at design conditions.

The designer may select a heat source based on available fuel types (e.g., gas, oil and electric), cost of the available fuel types, efficiency of operation, control options, the physical space allowed for the heat source, potential venting requirements, regulations and experience. Depending on the required water temperature for the radiant system, multiple types of heat sources may be the optimal solution.

The designer must also consider temperature limits of the floor structure, the flooring, wall or ceiling assemblies, and the pipe itself, and ensure that the heat source and/or heating water temperature controls will not deliver excessive fluid temperatures. Finally, the selected heat source must be compatible with the specified heating fluid which is either water or a water-glycol mixture.

Geothermal Heat Pump

Radiant heating is ideal for geothermal heat pump or ground source heat pump (GSHP) systems. Typically, water-to-water GSHP systems are capable of providing heating water temperatures as high as 120°F (49°C), satisfying the warm water temperature needs of many radiant systems.

Condensing Boilers

Condensing boilers, including modulating-condensing types, are typically designed to withstand condensation of flue gases caused by low return water temperatures of radiant systems.

Non-condensing Boilers

Non-condensing boilers are typically selected when the hydronic heating system has a combination of high temperature and low temperature heat emitters, such as a baseboard convector with a radiant heated floor. Non-condensing boilers must be paired with mixing controls to reduce the heating water temperature supplying the radiant system and at the same time protect the boiler from condensation due to the low returning water temperatures. Gas and oil fired boilers using cast iron, steel or copper heat exchangers generally fall into this category.

Electric Boilers

Electric boilers are compact, do not require exhaust ventilation, and may be a good match for most radiant systems. Boiler water supply temperatures can be controlled by a setting on the boiler without the addition of complicated mixing controls.

Outdoor Wood-fired Boilers

Outdoor wood-fired boilers are growing in popularity as a heat source for radiant systems. These boilers supply water temperatures that are too high for radiant systems, so they must be paired with a heat exchanger and mixing controls to reduce the water temperature.

Domestic Hot-water or Dual-purpose Tanks

Domestic hot-water or dual-purpose tanks are suitable in some applications when properly plumbed and when permitted by code. To ensure drinking water safety, heating system water must be prevented from mixing with domestic hot water.

Thermal Solar Collectors

Solar water heaters are growing in popularity as a heat source for radiant systems. Typically a large solar heated storage tank provides heating system water to the radiant system and may supply domestic hot water needs as well. Solar water heaters are usually paired with a gas, electric, gas or oil backup. Thermal solar collectors are used with a storage tank, heat exchanger and mixing controls which reduce the temperature of the water before it enters the radiant system.

Supplemental Heat

A radiant floor may not be able to supply the full heating load without exceeding the maximum radiant panel surface temperature or the maximum allowable flooring temperature. Some typical examples are:

- A bathroom where a large portion of the floor is covered with furniture or fixtures.
- A recreation room with a special species of hardwood flooring having a low material temperature limit

In these instances, the designer typically includes supplemental heat emitters such as a kickspace heater under a cabinet, a heated towel warmer in a bathroom, a baseboard radiator along the available wall space, or a fan coil with supply ductwork. These hybrid systems can be designed so that the supplemental heat emitter operates simultaneously with the radiant floor or can be controlled with a two-stage room thermostat, turning on the supplemental heat after the radiant floor has reached its heat output limit.

A better alternative for the designer is to use supplemental radiant panels in the walls or ceilings in areas that are not at risk for penetration by nails or screws. Examples include:

- Lower portions of walls
- Behind wall-mounted permanent mirrors
- Below tubs and shower pans
- On stairway landings and treads

5.9 Heating Water Controls

In a radiant heating system, controls are necessary to regulate the heating water flow and temperature according to the designed heat output of the radiant floor.

NOTICE: Check compatibility before allowing antifreeze, system additives or other chemicals to come in contact with the radiant heating system controls. Chemicals may damage mechanical and electro-mechanical controls resulting in leaks or operational failures.

Controls with built-in logic (e.g., thermostat, floor sensor, central zoning control, mixing control) can help a radiant system react faster to changes in the internal climate of an area. The construction method of the radiant panel has a significant effect on the response time of the radiant system. Radiant systems with high thermal masses (e.g., slab and overpour) typically have a slow response time at initial start up. Radiant systems and other hydronic heat emitters with low thermal masses (e.g., RAUPANEL, RAUPLATE, baseboard heating) have faster response times. Once the target ambient temperatures are achieved by the radiant systems, the heating tends to stay consistent.

Thermal Zoning Controls

Individual areas that correlate to piping contained in a radiant design can be controlled using thermostats, floor sensors, zone controls, pumps and zone valves or actuators.

Thermostats for radiant heating have two functions:

- Measure ambient air temperature
- Measure radiant panel temperature using a slab sensor embedded in the radiant panel

The thermostatic sensor in the radiant panel can limit the floor temperature so that temperature ratings of finished floor materials are not exceeded.

A zone may also incorporate an inline zone valve or zone pump which controls flow to an entire manifold or group of manifolds. Some manifolds incorporate flow control into each circuit, making it possible to regulate the flow of water for each circuit independently with the addition of a manifold valve actuator and room thermostat.

Mixing Controls

Radiant heating systems work at warm water temperatures. In systems that have high temperature heat sources, the lower temperature heating water is created by blending warm water returning from radiant heat circuits with hot water from the heat source. The hardware that controls this blending are called mixing controls. Mixing controls reduce the heating water temperature supplying the radiant heating system and protect non-condensing boilers from return water temperatures below 140°F (60°C).

Note: Failure to prevent sustained flue gas condensation in non-condensing boilers often results in massive scale formation on the fire side of the boiler's heat exchanger as well as aggressive corrosion of the boiler and the boiler's heat exchanger.

Heat sources that do not produce flue gases will not need this protection. Examples include electric boilers, hydronic heat pumps, thermal storage tanks and heat exchangers.

Weather Compensating Controls

Outdoor weather compensating controls, or outdoor reset controls, adjust the rate of heat delivery to more closely match the heat loss of a building, allowing the indoor air temperature to remain relatively constant. The outdoor reset control measures the outdoor air temperature, then calculates the target supply water temperature for the radiant system. This target supply temperature is constantly updated throughout the day as outdoor conditions change. The control can operate the heat source, mixing valve or a variable speed injection pump to adjust the heating water temperature toward the calculated target value.

5.10 Manifolds

Manifolds should be installed close to the heating zones in a convenient location for both the installation and for future accessibility. Several considerations when planning the location of the manifolds are:

- Does the manifold fit in the available space?
- What is the proximity to the heated areas (to reduce the length of pipe tails)?
- What is the proximity to the heat source (to minimize the distribution piping)?
- Is the location secure (to prevent tampering, especially in commercial and institutional installations)?
- Will the manifold be accessible in the future for maintenance, monitoring or adjustments?

There are many possibilities for manifold locations. Options include below the heating zones (mounted inverted) or on the same level as the heating zones, in mechanical rooms, in closets behind an access panel, below subfloors (mounted horizontally), underneath stairwells, inside cabinetry, in window boxes or benches behind an access panel, or in hallways in a recessed manifold cabinet.

5.11 Circulator Pumps

Circulator pumps should be sized to achieve the radiant system design flow rate. A pump that provides significantly higher flow velocity than required can cause noise and erosion problems within any steel or copper distribution pipes and can cause control failures by impeding closure of circuit or zone valves.

To size a pump, determine the required flow for the radiant heating system and the total friction losses to be overcome from all components. Use Tables 4.8-12 and 4.13 to estimate the pressure losses in pipes and fittings. Select the pump that is capable of achieving the system requirements using the pump manufacturer's operating curves.

NOTICE: The pump outlet pressure must not exceed the pipe ratings. Failure to follow this instruction may damage the pipe resulting in leaks and operational failures.

Effects of Elevation

With radiant heating system design, elevation is usually only relevant to the pressure rating of pipes and other hydronic components. The weight of the heating water in upper stories is cumulative and increases the pressure on pipes and components below. In closed-loop hydronic systems, where no heating water enters or leaves the piping system, elevation between the pump and radiant panel does not affect the sizing of the pump.

Example, given:

- 9-story building
- Static system pressure at highest elevation 15 psi
- Additional pressure from outlet side of pump 8 psi
- Mean heating water temperature 180°F (82°C)
- Assuming each story is 10 ft (3.3 m) high
- Water increases the pressure at each floor below by 0.44 psi per foot elevation

$$\text{TotalSystemPressure} = 15 + 9 \times 10 \times 0.44 + 8 = 63 \text{ psi}$$

✓ Checked system pressure is within the rating of the pipe, which is 100 psi at 180°F (82°C).

Note: Differences in heating water, such as antifreeze mixtures instead of 100% water, have higher densities, causing slightly greater pressure increases. Also, pressure at the pump outlet varies by pump model.

6. SYSTEM DESIGN

This chapter provides an overview of the radiant design process, highlighting key points to consider while designing a radiant system.

Laying out a radiant heating system design is a process using calculated values. The process is the same for a bedroom, a basement or an entire building. The equations used in the design process apply to new construction as well as renovations. The radiant design can be done with radiant design software, but it is important for the designer to understand how to design a system manually in order to optimize the system.

6.1 Step 1 - Gather Documents and Specs

The following information is required before beginning a radiant heating system design:

- Building drawings and specifications
- Heat loss calculation
- Room design temperatures

6.2 Step 2 - Determine Heat Output

Based on the heat loss calculation, calculate the radiant panel heat output requirement in Btu/h-ft² (W/m²) for each room or zone using the following formula:

$$PanelHeatOutput = \frac{Total\ Heat\ Loss}{Available\ Area}$$

Available area is normally less than total area. The designer must deduct non-heated areas where heating pipe cannot or should not be installed, such as under walls, refrigerators, kitchen islands or bookcases.

6.3 Step 3 - Determine Surface Temps

Calculate the radiant panel surface temperature that is needed to achieve the required heat output into the room. The panel surface temperature is the temperature at the outer surface of the finished floor, wall or ceiling.

To calculate the panel surface temperature in °F (°C), use the following equation:

$$PanelSurfaceTemp = \frac{PanelHeatOutput}{HTC} + Ambient\ Room\ Temp$$

The Heat Transfer Coefficient (HTC) is a combined radiant and convective coefficient that mainly depends on the type of panel being used. Some recommended values are:

- 2.0 Btu/h² for radiant floors (35-40% heat is transferred via natural convection)
- 1.8 Btu/h² for radiant walls (less natural convection than floors)
- 1.6 Btu/h² for radiant ceilings (very little natural convection)

These approximate values apply to typical ambient room temperatures in the range of 65 to 72°F (18 to 22°C). For colder rooms (e.g., a 55°F [13°C] warehouse) the HTC may be higher due to greater natural convection. For hotter rooms (e.g., an 80°F [27°C] greenhouse) the HTC may be lower.

6.4 Step 4 - Check Temperature Limitations

If the panel surface temperature exceeds the advisable temperature exposure limitations for occupants or the allowable floor covering temperatures, the designer can:

- Reduce the heat requirements by improving building envelope efficiency
- Increase the radiant panel surface area to include walls and/or ceilings
- Use supplemental heat (see Section 5.8)

When the maximum temperature of the floor covering must be limited, the designer can use an embedded floor temperature sensor to achieve the desired control.

Verify that human comfort limitations are not exceeded by checking conformity of the *PanelSurfaceTemp* to the values in Table 5.1.

Floor coverings offer a resistance to the heat transferred into the room, resulting in higher temperatures on the bottom than on the top of the finished floor. With the aid of Fig. 6.1, the designer can determine the resultant temperature on the underside of the finished floor.

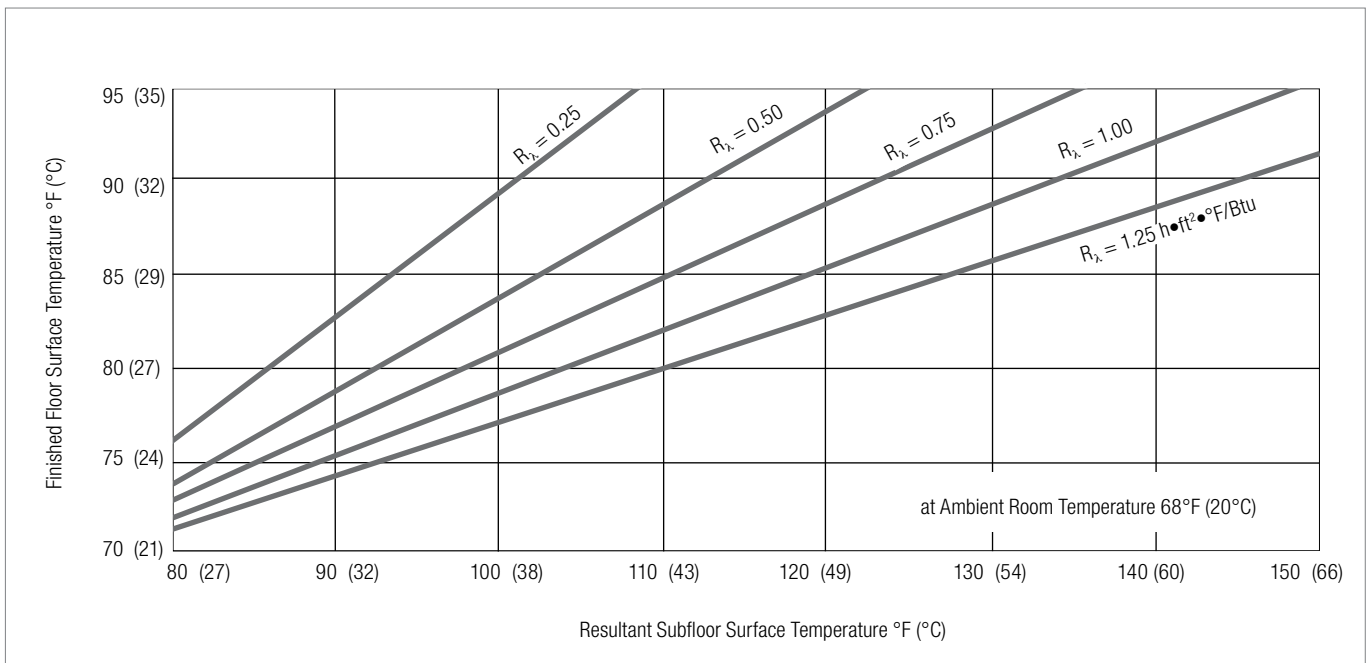

Fig. 6.1: Resultant subfloor surface temperature

Calculate the total floor covering resistance R_x by adding each R-value together. The floor covering resistance is an important component in the heat output and heating water temperature calculations for a radiant floor system. If the floor covering is unknown, do not directly use the "worst case scenario" because this may cause the system to be oversized. The designer should make the building owner aware of the importance of floor covering selection as it relates to proper radiant system performance.

Verify floor covering temperature limitations are not exceeded by converting the *PanelSurfaceTemp*, in combination with R_x , to a *SubFloorSurfaceTemp* with Fig. 6.1, then check that the *SubFloorSurfaceTemp* does not exceed the values in Table 5.2.

6.5 Step 5 - Select Construction Method

Determine the radiant panel construction method that is applicable for your project. There are applications which call for the use of wet, dry panel or dry plate construction methods. Fig. 6.2-6.3 detail various radiant heating construction methods.

Wet construction (poured) radiant heating systems have several advantages:

- Reduce air infiltration along exterior walls
- Provide excellent heat transfer properties; the pipe is in complete contact with the slab
- Even out temperature fluctuations caused by on/off cycling of the heat source
- Dampen sound transmission through the floor
- Improve the fire resistance rating of the floor
- Easy to subdivide the building into thermal zones

Dry panel radiant heating systems have several advantages:

- Easy to subdivide the building into thermal zones
- Excellent heat transfer properties
- Faster response time than overpour
- No overpour
- Low profile
- No changes to building structure required

Dry plate radiant heating systems have several advantages:

- Installed below existing flooring when retrofitting
- Installs quickly if there are few or no obstructions in the joist cavity
- No overpour

Fig. 6.2: Wet Construction - Overpour on Suspended Wood Floor With Plastic Staples

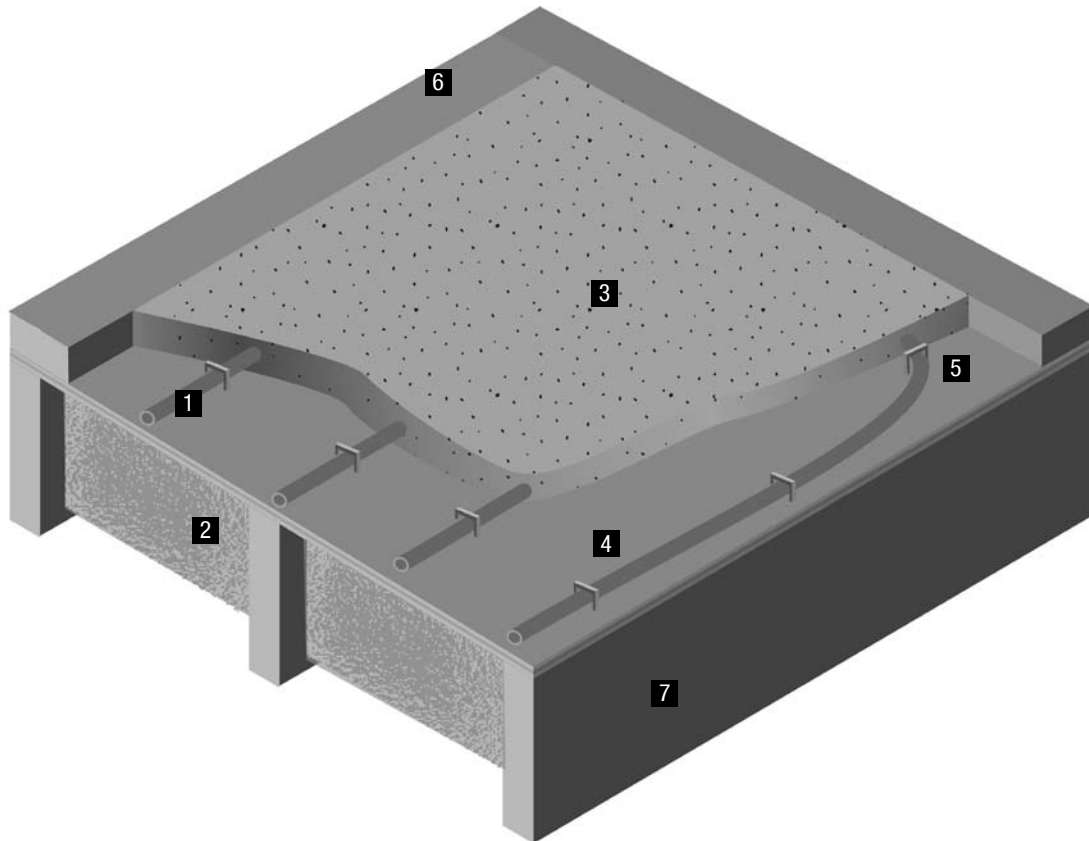

1 RAUPEX Pipe

2 Insulation - Recommend R-19 above heated spaces and R-30 above unheated spaces to direct heat upwards. Local codes may have insulation minimums. Recommend insulation be installed up against the subfloor with no gaps.

3 Thermal Mass - Minimum 3/4 in (19 mm) coverage over the top of the pipe to avoid striping and cracking. Portland concrete or gypsum cement are acceptable thermal masses. Fibers may be used in the mix but not vermiculite or entrained air. Follow manufacturer's guidelines for installing the thermal mass.

4 Plastic Staples - Typically fasten every 2 to 3 ft. Ensure bends and turns are secured.

5 Subfloor With Barrier - A barrier is applied to the subfloor before installation of the radiant heating system. Use 4 to 6 mil polyethylene film with portland cement. Use a manufacturer recommended sealer with gypsum concrete.

6 Baseplate - Recommend keeping pipe 6 in (15 cm) from walls as these areas may become nailing surfaces later during construction.

7 Floor Joists - Floor must be designed to carry the additional loading from the overpour.

Fig. 6.3: Dry Plate Construction - RAUPLATE Within Suspended Wood Floor

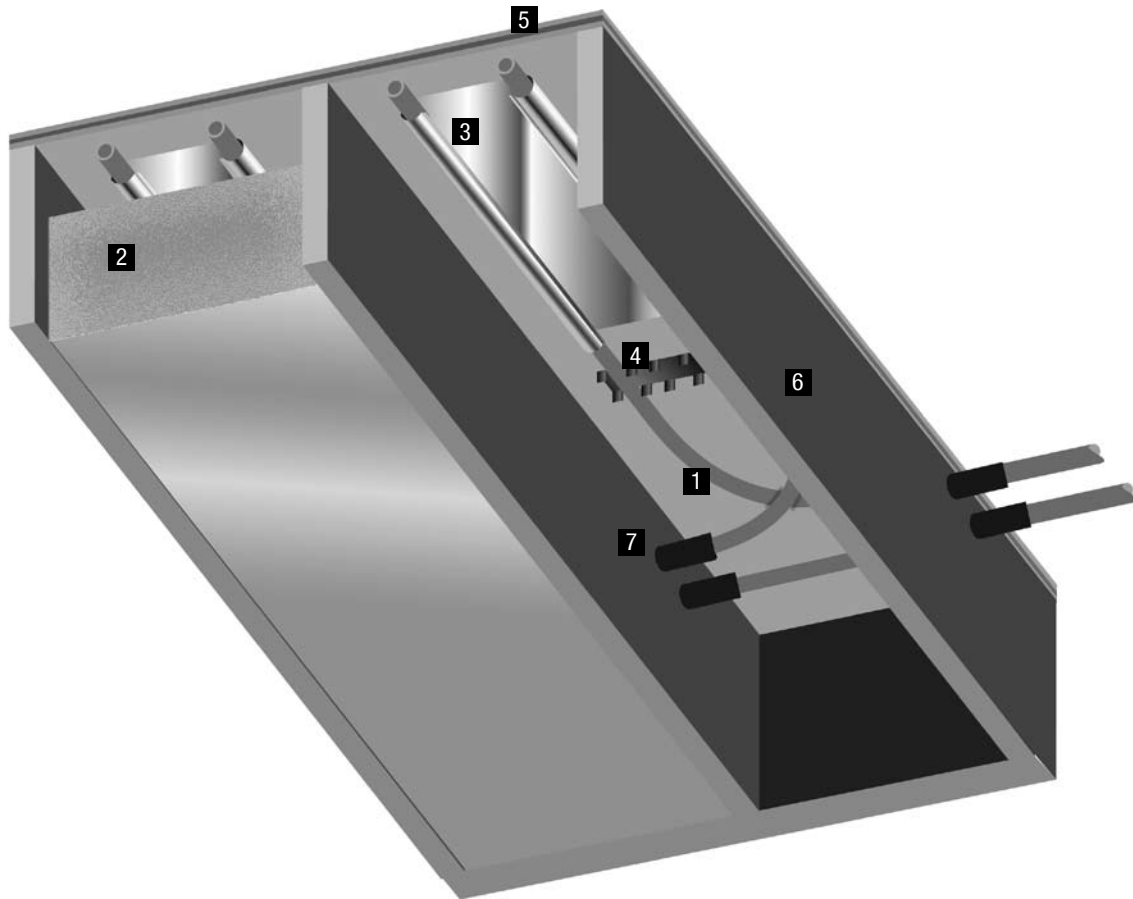

1 RAUPEX Pipe - Snaps securely into the RAUPLATE channels without adhesives or fasteners. When transitioning from the joist penetration to the heat transfer plates, criss-crossing the pipes increases the bending radius and makes them easier to install.

2 Insulation - Recommend R-19 above heated spaces and R-30 above unheated spaces to direct heat upwards. Local codes may have insulation minimums. Ensure 2 to 4 in (5 to 10 cm) air gap between the pipe and the top of the insulation. At the ends of each joist cavity, seal openings and insulate thoroughly to prevent lateral air currents.

3 RAUPLATE - Attach heat transfer plates to underside of subfloor with six screws. Leave 1 in (25 mm) spacing between plates.

4 Fixing Rail - Secures the pipe to the underside of the subfloor when transitioning to/from the RAUPLATE. Leave 4 in (10 cm) between the fixing rail and RAUPLATE.

5 Subfloor - Remove protruding staples and screws through the underside of the subfloor in the areas where the pipes and plates are to be installed.

6 Floor Joists - Before boring joist penetrations, check with the building owner and local codes to be sure the holes are acceptable.

7 PE Protection Sleeve - Recommend sleeving pipes when passing through joists to reduce abrasion and noise caused by expansion and contraction.

6.6 Step 6 - Select Pipe Size

There are five choices when selecting pipe size for your radiant heating system.

Select a pipe size for the radiant panel. Subsequent steps in the design process may result in the designer increasing or decreasing the pipe size to optimize the radiant system performance.

Table 6.1: Pipe Sizes

Pipe Size	Typical Applications	Typical Total Circuit Lengths
3/8 in	Dry panel and joist-space systems	up to 250 ft (76 m)
1/2 in	Residential poured systems	up to 330 ft (101 m)
5/8 in	Large residential and small commercial poured systems	up to 400 ft (122 m)
3/4 in	Commercial and industrial systems	up to 500 ft (152 m)
1 in	Large commercial and industrial systems	greater than 500 ft (152 m)

6.7 Step 7 - Select Pipe Spacing

The heating system must not only fulfill the task of meeting the heat requirement but also create a sense of comfort. The heat requirement of a room is higher near exterior walls (perimeter areas) and diminishes toward the center of the room (occupied area). The most efficient radiant designs separate the perimeter zone along the outside walls from the occupied area(s) in the center of the room. The higher heat requirement at exterior walls and windows can usually be met by decreasing the pipe spacing in comparison to the occupied area. Pipe spacing is selected to provide even floor surface temperatures and fast response time while using the lowest fluid temperature. Generally, the heat requirement of a room may be achieved regardless of the pipe layout pattern.

REHAU recommends the pipe spacing be selected to provide the most comfortable floor surface temperature and the most energy efficient system. Closer pipe spacing improves the uniformity of the floor surface temperature and lowers the heating water temperature, resulting in greater energy efficiency.

Advantages of closer pipe spacing are:

- Allows for a lower fluid temperatures, increasing the efficiency of the heat source
- Increases the heat output of the radiant panel at a given heating water temperature
- Provides faster response time
- Provides more even surface temperature

Considerations with larger pipe spacing are:

- Requires a higher water temperature to achieve the same output
- May result in striping (concentrated hot and cold spots)

Select a pipe spacing for the radiant panel. Subsequent steps in the design process may result in the designer increasing or decreasing the pipe spacing to optimize the radiant system performance.

Table 6.2: Typical Pipe Spacing for 3/8, 1/2 or 5/8 in. RAUPEX

Construction Method	Typical Pipe Spacing
Slab-on-grade, commercial	Depends on heat loss, up to 18 in (45 cm) possible
Slab-on-grade, residential	Perimeter 6-8 in (15-20 cm), occupied 12 in (30 cm), bathrooms 6 in (15 cm)
Overpour, residential	Perimeter 6-8 in (15-20 cm), occupied 6-12 in (15-30 cm)
– Overpour with tile	6-9 in (15-23 cm) spacing throughout to prevent striping
– Overpour with carpet	Perimeter 6-8 in (15-20 cm), occupied up to 12 in (30 cm) based on heat load
– Overpour in bathrooms	6 in (15 cm) spacing throughout for high output
– Under cabinets on exterior walls	12 in (30 cm) under all "cold wall" cabinets
– Under cabinets in interior areas	Usually no pipe here
Dry panel	Usually 8 in (20 cm) throughout (6 in [15 cm] for higher heat loss)
Dry plate (joist space)	8 in (20 cm) spacing throughout

6.8 Step 8 - Determine Pipe Length

There is no absolute maximum circuit length. However, practical maximum circuit lengths do exist. These depend on the pipe size, heat loss and pump capability to keep the heating water temperature differential below 20°F (11°C). Keep the following in mind:

- The farther the heating water goes in the pipe, the colder it becomes
- The faster the flow rate, the lower the drop in heating water temperature
- The smaller the pipe, the higher the pressure loss

The radiant heating distribution manifold and the radiant heating panels are usually located in different areas of a building. The pipes between the manifold and the radiant panel are called circuit tails. You must add the circuit tails to the radiant panel pipe circuit length to properly calculate the total pressure requirement for the circuit.

Table 6.3: Pipe Length Chart

Pipe Spacing	Approximate Pipe Length	
	per sq-ft of floor space	per sq-m of floor space
2 in (5 cm)	6 ft	20 m
4 in (10 cm)	3 ft	10 m
6 in (15 cm)	2 ft	6.6 m
8 in (20 cm)	1.5 ft	4.9 m
9 in (23 cm)	1.3 ft	4.4 m
10 in (25 cm)	1.2 ft	3.9 m
12 in (30 cm)	1 ft	3.3 m

Determine the number of circuits for the radiant panel, the length of each circuit and the length of each circuit's tails. Table 6.3 can be used to quickly estimate the circuit length for a given floor space and pipe spacing.

$$TotalCircuitLength = Panel\ Circuit\ Length + Circuit\ Tail\ Length$$

Verify total pipe length is below the practical limitations by checking the *TotalCircuitLength* does not exceed the value in Table 6.1.

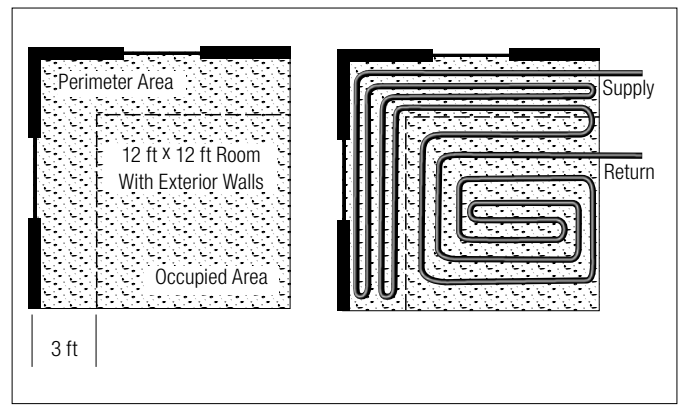

Fig 6.4: Overpour with perimeter and occupied areas using one circuit

Example, using Fig. 6.4:

Perimeter Area	6 in. on-center spacing 3 ft x 12 ft + 3 ft x 9 ft = 63 sq-ft Circuit Length = 63 x 2 = 126 ft
Occupied Area	12 in. on-center spacing 9 ft x 9 ft = 81 sq-ft Circuit Length = 81 x 1.0 = 81 ft
Circuit Tails	assume manifold is 20 ft from living room
<i>TotalCircuitLength</i> = 126 + 81 + 2 x 20 = 247 ft	

Subsequent steps in the design process may result in the designer increasing or decreasing the pipe length and number of circuits to optimize the radiant system performance.

6.9 Step 9 - Calculate Heating Water Temp

REHAU recommends the lowest heating water temperature that will provide the required panel surface temperature. This will minimize thermal stress on slabs and floor coverings, and minimize overshooting of the desired ambient room temperature.

The heating water temperature that is required will provide the necessary amount of heat into the room. The heating water temperature is described in terms of the mean heating water temperature (MHWT) and the heating water temperature differential (ΔT). MHWT is the average temperature of the supply and return heating water for the radiant heating panel.

Floor coverings can have a significant impact on the MHWT. Highly resistive floor coverings (e.g., carpet and padding) require the water temperature to be increased to overcome the resistance to heat flow through the floor. Highly conductive floor coverings (e.g., tile) require a lower water temperature to provide the same heat output.

The heating water temperature is determined using the ambient room temperature from the building specifications and the selected construction method, pipe size and pipe spacing.

Calculate the heat output of the panel using the REHAU Radiant Heating Performance Diagrams for the given conditions to calculate the MHWT.

Example, given:

- 12 ft x 12 ft living room space with 3,600 Btu/h heat requirement
- Ambient Room Temp = 68°F
- Floor covering of thin carpet with padding ($R_x=1.0 \text{ h-ft}^2\text{-}^\circ\text{F/Btu}$)
- Lightweight 1.5 in. overpour above suspended wood floor
- 1/2 in. RAUPEX with 6 in. on-center spacing

$$\text{PanelHeatOutput} = \frac{3,600}{12 \times 12} = 25 \text{ Btu/h - ft}^2$$

Differential Temperature of 62°F from Fig 6.5

$$\text{MHWT} = 62 + 68 = 130^\circ\text{F}$$

Optimizing the MHWT may require changing previously selected values for pipe size and spacing. The designer will need to reiterate the previous calculations with the newly selected values.

Select the ΔT for the radiant panel. Typical hydronic designs are based on 20°F (11°C) or 10°F (6°C). REHAU radiant heating performance tables/graphs are based on 20°F (11°C).

Calculate the supply and return heating water temperatures for the radiant panel.

$$\text{Manifold Supply Temp} = \text{MHWT} + 1/2 \times \Delta T$$

$$\text{Manifold Return Temp} = \text{MHWT} - 1/2 \times \Delta T$$

In certain instances, the manifold supply water temperature is limited due to the heat output of the heat source. When this occurs, the temperature limit of the heat source is used to establish the MHWT.

6.10 Step 10 - Calculate Heating Water Flow

Calculate the heating water flow for each circuit using the panel heat loss, the heating water temperature differential and the properties of the heating water.

$$\text{FlowRate} = \frac{\text{TotalHeatLoss}}{60 \text{ min/h}} \times \frac{1}{\Delta T} \times \frac{1}{\gamma \times C_p}$$

where:

- γ is the specific weight of the heating water at MHWT
- C_p is the heating capacity of the heating water

Example, given:

- Total Heat Loss of 3,600 Btu/hr
- 120°F MHWT, 20°F ΔT and 100% water
- 8.25 lb/USGPM specific weight of water @ 120°F
- 1.0 Btu/lb-°F heat capacity of water

$$\text{FlowRate} = \frac{3,600}{60} \times \frac{1}{20} \times \frac{1}{(8.25 \times 1)} = 0.4 \text{ USGPM}$$

Heating water properties change when adding antifreeze and at different mean hot water temperatures.

6.11 Step 11 - Size Manifold

Manifolds are selected according to the pipe size, number of circuits and circuit flow rates. Smaller manifolds (up to 6 circuits), in various building locations, are usually preferred to a large, central manifold (such as 10, 11, 12 or more circuits). With large manifolds, the designer should consider the effect of manifold location on the radiant heating system design (Section 5.12) and the impact of bringing many pipes in to one area. For example, a 12 circuit manifold has 24 inlet/outlet pipes which result in a congested pipe layout and an excessively warm area near the manifold.

Determine the number of circuits for each manifold. Zoning the building usually increases the number of circuits resulting in manifolds with more outlets.

Calculate the distribution flow rate of the manifold for the selected number of circuits using the formula below. Verify the *ManifoldFlowRate* does not exceed the maximum allowable in Table 4.1.5.

$$\begin{aligned} \text{ManifoldFlowRate} &= \sum \text{CircuitFlowRates} \\ &= \text{CircuitFlowRate1} + \text{CircuitFlowRate2} + \dots \end{aligned}$$

6.12 Step 12 - Locate Manifold

Identify the manifold location before beginning the pipe layout. Manifolds must always be installed within the heated space, and not be located in an unheated area.

Fig. 6.5: Radiant Heating Performance Diagram - Lightweight Concrete 1.5 in (38 mm) Overpour With 1/2 in RAUPEX

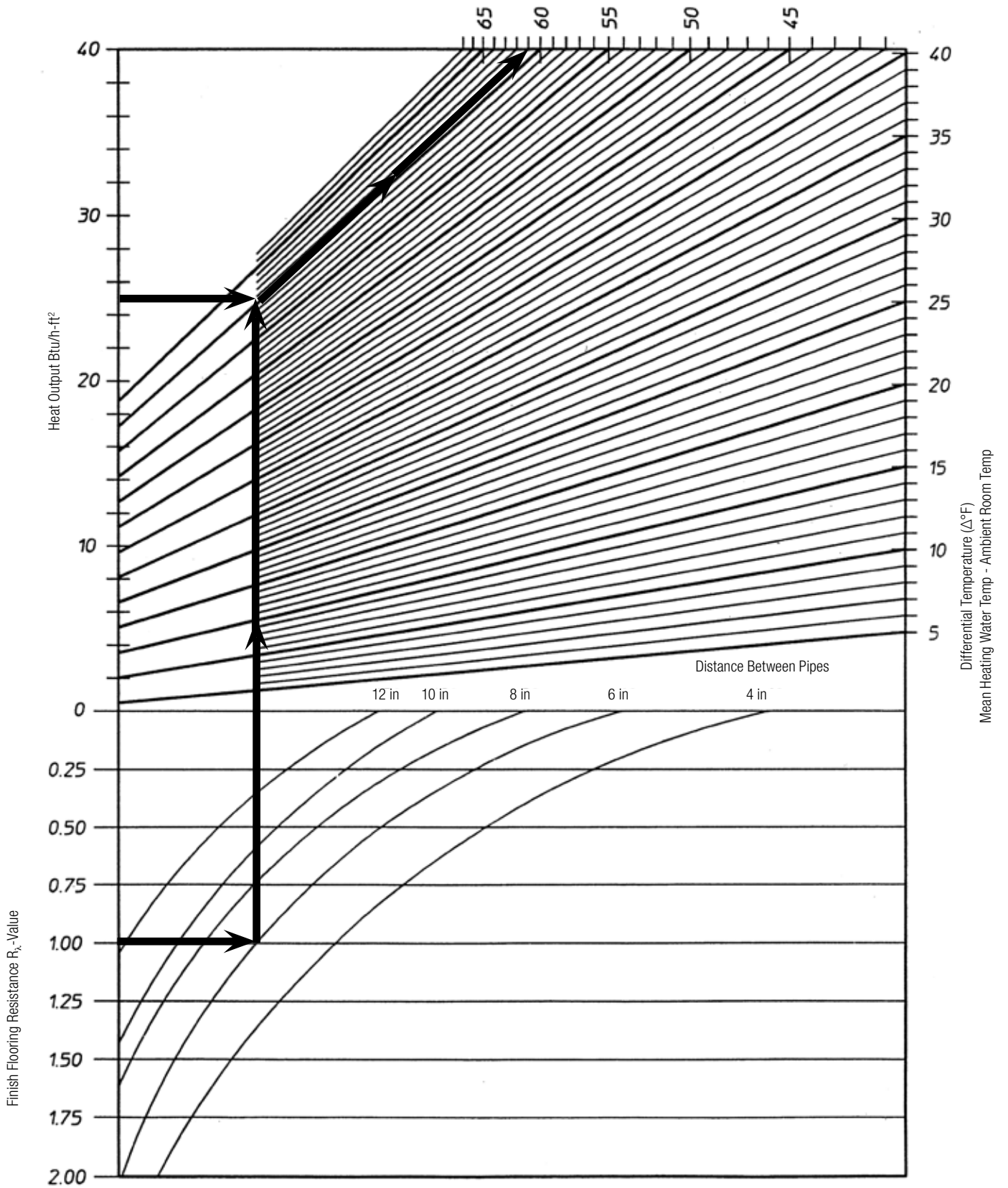

Additional Radiant Heating Performance Diagrams may be obtained by contacting your regional REHAU sales office.

6.13 Step 13 - Layout Pipe

An optimal radiant heating system design not only fulfills the heat requirements but also creates a sense of comfort. Heat requirements are higher near exterior walls and windows and diminish toward the center of the room. Following are some basic pipe layout recommendations:

- Do not run pipes under built-ins (e.g., cabinets, window seats, large appliances, raised hearths, stairs)
- Keep pipes a minimum of 6 in (15 cm) away from the edge of the slab, walls and nailing surfaces, and other locations where plates, fixtures or built-ins might be fastened into the floor
- Keep balanced circuit lengths within 10% of each other
- Design separate circuits for different rooms, allowing better room temperature control
- Keep area types reasonably sized
- Do not run circuit pipes across movement joints
- Select the pipe size that is large enough for the application (e.g., 1 in. pipes allow for 600 ft [183 m] circuit lengths for applications such as aircraft hangars and large industrial buildings)

The heating circuit may be laid in a variety of patterns. Often the most effective way to heat a room is to use a serpentine pattern at the edges and a counter flow spiral pattern in the middle. There are many ways these basic patterns can be combined to meet the unique requirements of any project. In principle, the heat requirement of a room can be achieved regardless of the layout pattern.

Counter Flow Spiral

With fewer bend radius constraints, counter flow spirals allow closer pipe spacing and distribute heat more evenly than serpentine patterns.

Serpentine

A serpentine pattern provides more heat to the perimeter areas than to the interior of the room, where occupants are more likely to gather.

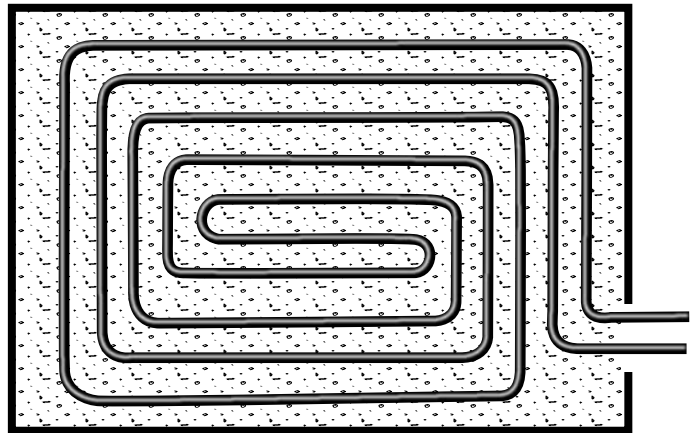

Fig. 6.6: Counter flow spiral pipe layout

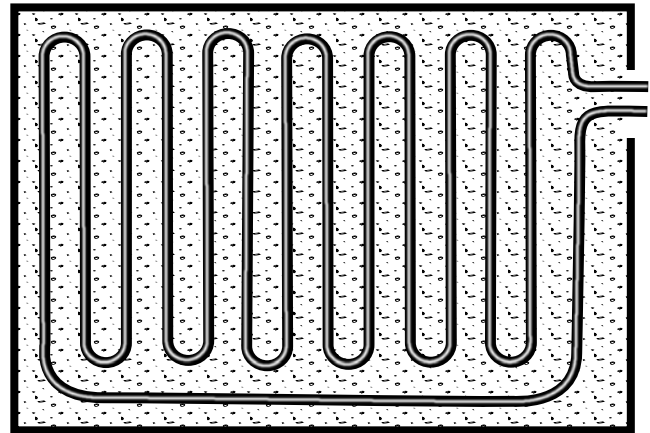

Fig. 6.7: Serpentine pipe layout

7. SYSTEM TESTING

A pressure test must be performed on the system to ensure the RAUPEX pipe and connections are leak-free. Local jurisdictions may have additional testing requirements.

For wet construction methods, the pressure test must be performed prior to and during the installation of the thermal mass. For dry construction methods, the pressure test must be performed prior to and during the installation of the floor, wall and ceiling coverings. Typically, the system is filled with water and pressurized to 1.5 times the operating pressure or 100 psi (6.9 bar), whichever is greater.

NOTICE: If there is a chance that the water could freeze, use a water/glycol mixture when filling the system or performing an air test. Frozen pipes may burst resulting in leaks and operational failures.

Refer to the REHAU *Radiant Heating Installation Guide* for instructions on performing the purging and pressure testing.

For updates to this publication, visit na.rehau.com/resourcecenter

The information contained herein is believed to be reliable, but no representations, guarantees or warranties of any kind are made as to its accuracy, suitability for particular applications or the results to be obtained therefrom. Before using, the user will determine suitability of the information for user's intended use and shall assume all risk and liability in connection therewith.

© REHAU 2010